

Autonics

TEMPERATURE INDICATOR T3NI/T4YI/T4WI/T4WM SERIES

M A N U A L



Thank you very much for selecting Autonics products.
For your safety, please read the following before using.

Caution for your safety

- *Please keep "Caution for your safety" to avoid accidents or damages as using it correctly.
- *The meaning of 'Warning' and 'Caution' is as follows:
Warning In case a serious injury or dead may be occurred.
Caution In case a little injury or damage of this unit may be occurred.
- *The meaning of the mark on the product and manual is as follows:
 is a caution mark for danger in special condition.

Warning

- Please use it with double safety devices when it is used at the equipments which may cause damages to human life or assets. (Ex:Nuclear power, Medical equipment, Vehicle, Train, Air plane, Combustion apparatus, Entertainment or Safety device etc.) It may cause a fire, human life or assets.
- This equipment must be mounted on panel. It may give an electric shock.
- Do not repair or checkup when power on. It may give an electric shock.
- Do not disassemble and modify, when it requires. If needs, please contact us. It may give an electric shock and cause a fire.
- Please check the terminal No. when connect. It may cause a fire.
- Lithium battery is used for memory retention in T4WM, therefore do not disassemble or burn it. It may cause a fire.
- This product is a combined use of 110/220VAC, please check the terminal when connect. It may cause a fire.

Caution

- This equipment shall not be used outdoors. It might shorten the life cycle of the product or give an electric shock.
- When wire connection, No. 20AWG(0.50mm²) should be used and screw bolt on terminal block with 0.74N·m to 0.90N·m strength. It may result in malfunction or fire due to contact failure.
- Please observe specification rating. It might shorten the life cycle of the product and cause a fire.
- In cleaning the unit, do not use water or an oil-based detergent. It might cause an electric shock or fire that will result in damage to this product.
- Do not use this unit at place where there are flammable or explosive gas, humidity, direct ray of the sun, radiant heat, vibration, impact etc. It may cause a fire or explosion.
- Do not inflow dust or wire dregs into inside of this unit. It may cause a fire or mechanical trouble.
- Please wire properly after checking the polarity of terminals when connect thermocouples. It may cause a fire or explosion.

*The above specification are changeable without notice anytime.

Ordering information

① Product	T	Temperature
② Display	3	3 Digit
	4	4 Digit
③ Size	N	DIN W48 × H24mm
	Y	DIN W72 × H36mm
	W	DIN W96 × H48mm
④ Sub output mode	I	Indicator Type
	M	5 Point Indicator
⑤ Control mode	N	No output
	X	12-24VDC
⑥ Power supply	3	110/220VAC 50/60Hz
	4	100-240VAC 50/60Hz
⑦ Output mode	N	No output
	K	K(CA) Type
	J	J(IC) Type
	P	Pt100Ω
⑧ Sensor input type	0	-99.9 to 199.9
	4	0 to 399
	5	0 to 500
	C	0 to 1200
⑨ Temperature range	0	-99.9 to 199.9
	4	0 to 399
	5	0 to 500
	C	0 to 1200
⑩ Unit	C	°C

Specifications

Model	T3NI	T4YI	T4WI	T4WM
Power supply	12-24VDC	100-240VAC 50/60Hz	110/220VAC 50/60Hz	
Allowable operating voltage	90 to 110% of rated voltage			
Power consumption	2W	3VA		
Display method	7 Segment LED Display			
Display accuracy	F · S ± 0.3% rdg ± 1digit	F · S ± 0.5% rdg ± 1digit		
Input sensor	RTD : Pt100Ω	Thermocouples : K(CA), J(IC), Pt100Ω		
Input line resistance	RTD:Max. 5Ω per a wire	Thermocouples : Max. 10Ω RTD : Max. 5Ω per a wire		
Available sensor quantity				Thermocouple: Max. 5pcs RTD:Max. 5pcs
Insulation resistance	Min. 100MΩ (at 500VDC)			
Dielectric strength	2000VAC 50/60Hz for 1 minute			
Noise strength	± 2kV the square wave noise(pulse width:1μs) by the noise simulator		± 1kV	
	± 500V		± 1kV	
Vibration	Mechanical	0.75mm amplitude at frequency of 10 to 55Hz in each of X, Y, Z directions for 1 hour		
	Malfunction	0.5mm amplitude at frequency of 10 to 55Hz in each of X, Y, Z directions for 10 minutes		
Shock	Mechanical	300m/s ² (Approx. 30G) 3 times at X, Y, Z direction		
	Malfunction	100m/s ² (Approx. 10G) 3 times at X, Y, Z direction		
Ambient temperature	-10 to 50°C (at non-freezing status)			
Storage temperature	-25 to 65°C (at non-freezing status)□			
Ambient humidity	35 to 85%RH			
Weight	Approx. 34g	Approx. 170g	Approx. 322g	

Temperature range for each sensor

Model	T4YI / T4WI / T4WM		
	RTD Pt100Ω	Thermocouples J(IC)	Thermocouples K(CA)
Standard scale range (°C)	1600	1200	1200
	1200	1000	1000
	800	800	800
	600	600	600
	400	400	400
	399.9	500	399.9
	200	200	200
	100	100	100
	0	0	0
	-99.9	-99.9	-99.9

Dimensions

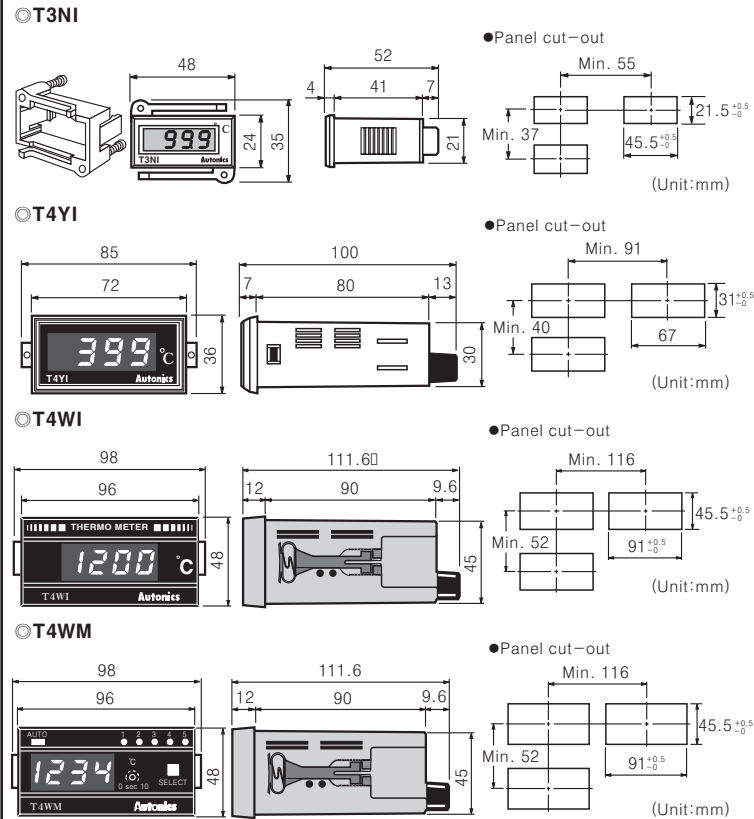

Connection

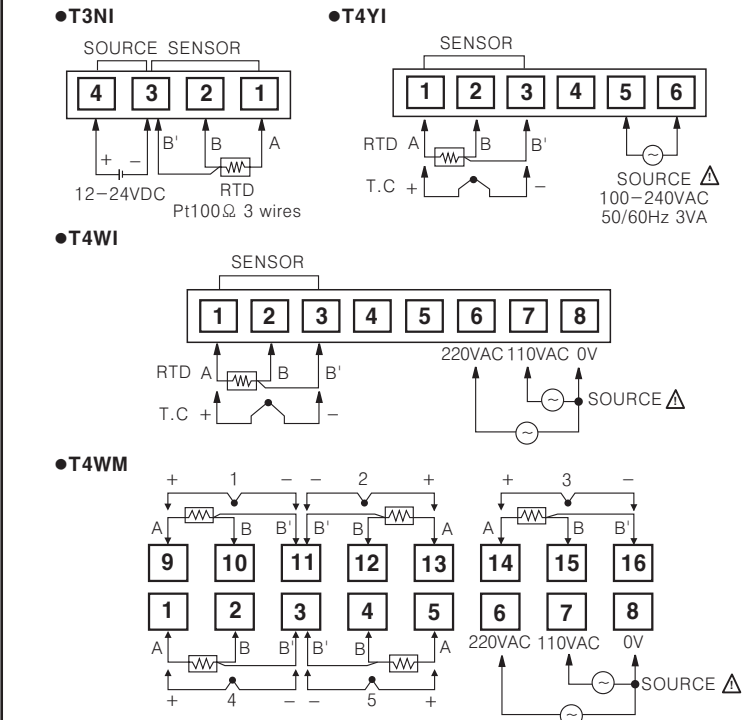

Parts name(T4WM)

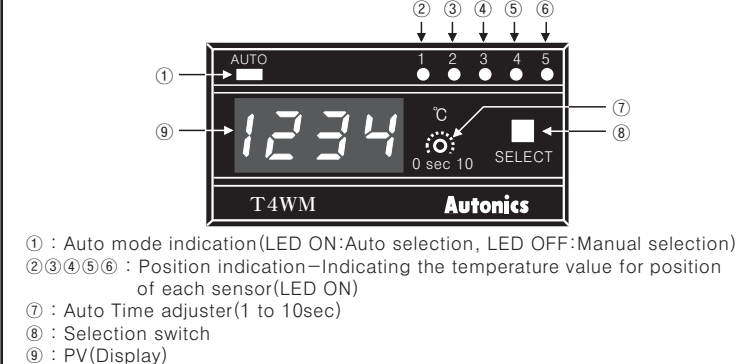

5 Point indicator(T4WM)

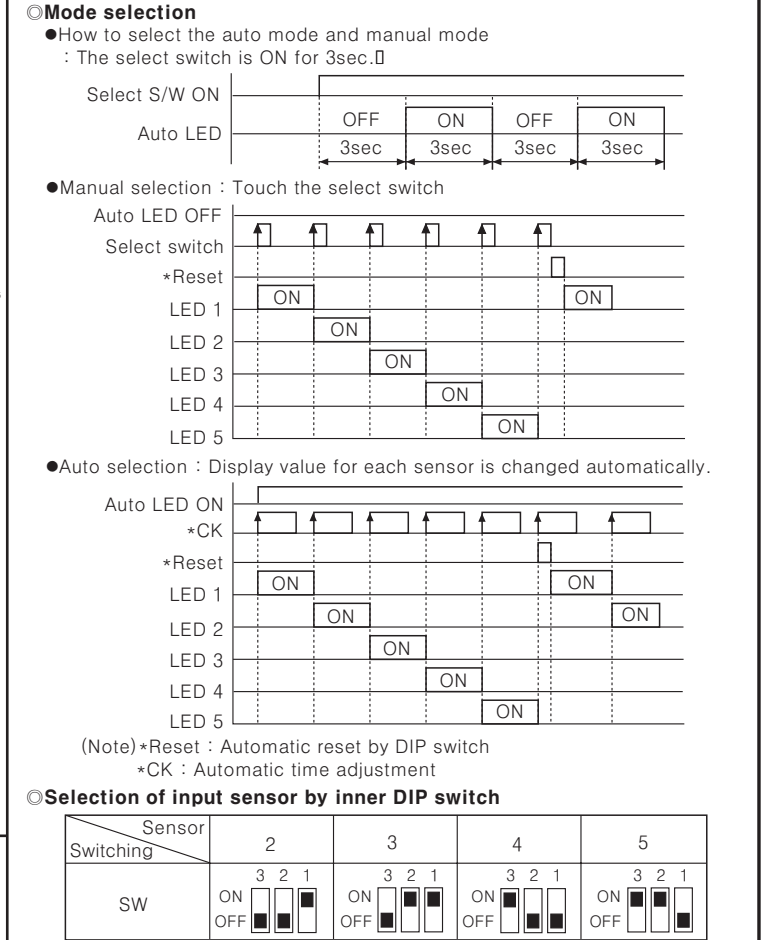

Caution for using

- Installation environment
 - It shall be used indoor
 - Altitude Max. 2000m
 - Pollution Degree 2
 - Installation Category II.
 - Please use the terminal(M3.5, Max.7.2mm) when connect the AC power source.
 - Please use separated line from high voltage line or power line in order to avoid inductive noise.
 - Please install power switch or circuit-breaker in order to cut power supply off.
 - The switch or circuit-breaker should be installed near by users.
 - Do not use this product as Volt-meter or Ampere-meter, this is a temperature controller.
 - Be sure to use compensating wire when extends wire from controller, otherwise the temperature deviation will be occurred at the part where wires are connected each other.
 - In case of using RTD sensor, 3wires type must be used. If it needs to extend the line, 3wires must be used with the same thickness as the line. It might cause the deviation of temperature if the resistance of line is different.
 - In case of making power line and input signal line close, line filter for noise protection should be installed at power line and input signal line should be shielded.
 - Keep away from the high frequency instruments. (High frequency welding machine & sewing machine, big capacitive SCR controller)
- *It may cause malfunction if above instructions are not followed.

Main products

- COUNTER
- TIMER
- TEMPERATURE CONTROLLER
- PANEL METER
- TACHO/LINE SPEED/PULSE METER
- DISPLAY UNIT
- PROXIMITY SENSOR
- PHOTOELECTRIC SENSOR
- FIBER OPTIC SENSOR
- PRESSURE SENSOR
- ROTARY ENCODER
- SENSOR CONTROLLER
- POWER CONTROLLER
- STEPPING MOTOR & DRIVER & CONTROLLER

Autonics Corporation
<http://www.autonics.net>

HEAD QUARTER :
 41-5, Yongdang-ri, Uingsang-eup, Yangsan-si, Gyeongnam, Korea 626-847

INTERNATIONAL SALES :
 512 Ansung B/D, 410-13, Shindorim-dong, Guro-gu, Seoul, Korea 152-070
 TEL:82-2-2679-6585 / FAX:82-2-2679-6556
 E-mail : sales@autonics.net

NO20030821-EP-KE-03-0040E

Autonics

TEMPERATURE CONTROLLER T4L/T4LA/T4LP SERIES

M A N U A L



Thank you very much for selecting Autonics products.
For your safety, please read the following before using.

Caution for your safety

- Please keep these instructions and review them before using this unit.
- Please observe the cautions that follow:
 - Warning** Serious injury may result if instructions are not followed.
 - Caution** Product may be damaged, or injury may result if instructions are not followed.
- The following is an explanation of the symbols used in the operation manual.
 - Caution: Injury or danger may occur under special conditions.

Warning

- In case of using this unit with machineries (Nuclear power control, medical equipment, vehicle, train, airplane, combustion apparatus, entertainment or safety device etc), it requires installing fail-safe device, or contact us for information on type required. It may result in serious damage, fire or human injury.
- This unit must be mounted on panel. It may give an electric shock.
- Do not repair or checkup when power on. It may give an electric shock.
- Do not disassemble and modify this unit, when it requires. If needs, please contact us. It may give an electric shock and cause a fire.
- This product is a combined use of 110/220VAC, please check the terminal whe connect. It may cause a fire.

Caution

- This unit shall not be used outdoors. It might shorten the life cycle of the product or give an electric shock.
- When wire connection, No.20AWG(0.50mm²) should be used and screw bolt on terminal block with 0.74N·m to 0.90N·m strength. It may result in malfunction or fire due to contact failure.
- Please observe specification rating. It might shorten the life cycle of the product and cause a fire.
- Do not use the load beyond rated switching capacity of Relay contact. It may cause insulation failure, contact melt, contact failure, relay broken, fire etc.
- In cleaning the unit, do not use water or an oil-based detergent. It might cause an electric shock or fire that will result in damage to this product.
- Do not use this unit at place where there are flammable or explosive gas, humidity, direct ray of the sun, radiant heat, vibration, impact etc. It may cause a fire or explosion.
- Do not inflow dust or wire dregs into inside of this unit. It may cause a fire or mechanical trouble.
- Please wire properly after checking the polarity of terminals when connect thermocouples. It may cause a fire or explosion.

Dimensions

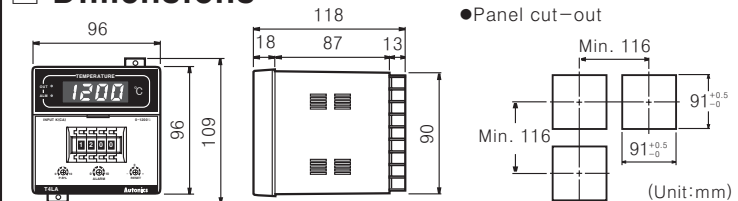

Connections

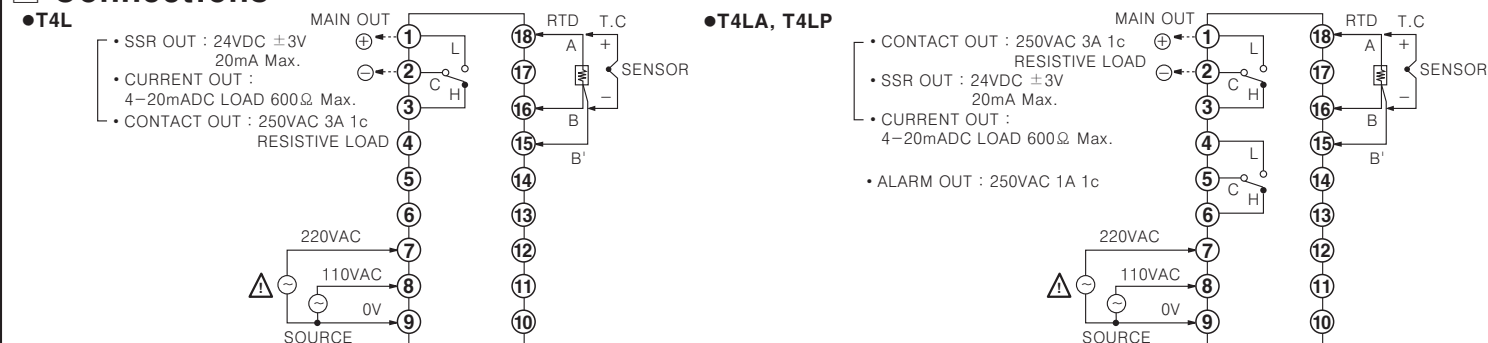

*The above specification are changeable without notice anytime.

Ordering information

① Item	T	Temperature
② Digit	4	4 Digit
③ Size	L	DIN W96 × H96mm
④ Alarm/Sub output mode	A	Alarm output(High·Low)
	P	Double output
⑤ Control mode	B	ON/OFF, Proportional control
⑥ Power supply	3	110/220VAC 50/60Hz
⑦ Output mode	R	Relay output
	S	SSR output
	C	Current output(4-20mADC)
⑧ Sensor input type	K	K(CA) Type
	J	J(IC) Type
	R	R(PR) Type
	P	Pt100Ω
⑨ Temperature range	0	-99.9 to 199.9
	1	0 to 99.9
	2	0 to 199.9
	4	0 to 399
	8	0 to 799
	C	0 to 1200
	F	600 to 1600
⑩ Unit	C	°C

Specifications

Model	T4L	T4LA	T4LP
Power supply	110/220VAC 50/60Hz		
Allowable voltage range	90 to 110% of rated voltage		
Power consumption	3VA		
Display method	7 Segment LED Display		
Display accuracy	F·S ±0.5% rdg ±1digit		
Setting method	Digital setting		
Setting accuracy	F·S ±0.5%		
Sensor input	Thermocouples:K(CA), J(IC), R(PR)/RTD:Pt100Ω		
Input line resistance	Thermocouples:Max. 100Ω, RTD:Max. 5Ω per a wire		
Control	ON/OFF	Hysteresis:F·S 0.2 to 3% variable	
	Proportional	Proportional band:F·S 1 to 10% variable, Period:20sec. fixed	
	Alarm	F·S 0 to 10% variable	
Reset VR range	F·S ±3% variable(Correction of control deviation)		
Control output	<ul style="list-style-type: none"> Relay contact output:250VAC 3A 1c SSR output:24VDC ±3V 20mA max. Current output:4-20mADC(Load 600Ω max.) Alarm contact output:250VAC 1A 1c(T4LA) Double contact output:250VAC 2A 1c(T4LP) 		
Self-diagnosis	Built-in burn out function		
Insulation resistance	Min. 100MΩ(at 500VDC)		
Dielectric strength	2000VAC 50/60Hz for 1 minute		
Noise strength	±2kV the square wave noise(pulse width:1μs) by the noise simulator		
Vibration	Mechanical	0.75mm amplitude at frequency of 10 to 55Hz in each of X, Y, Z directions for 1 hour	
	Malfunction	0.5mm amplitude at frequency of 10 to 55Hz in each of X, Y, Z directions for 10 minutes	
Shock	Mechanical	300m/s ² (Approx. 30G) 3 times at X, Y, Z direction	
	Malfunction	100m/s ² (Approx. 10G) 3 times at X, Y, Z direction	
Relay life cycle	Mechanical	Min. 10,000,000 times	
	Electrical	Min. 100,000 times(250VAC 3A resistive load)	
Ambient temperature	-10 to 50°C(at non-freezing status)		
Storage temperature	-25 to 65°C(at non-freezing status)		
Ambient humidity	35 to 85%RH		
Weight	Approx. 468g	Approx. 484g	Approx. 487g

Temperature range for each sensor

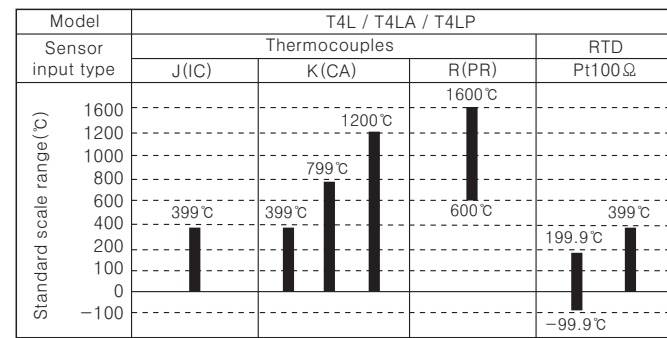

ON/OFF control

The drawing shows that the output turns on when the temperature is lower than the set value.(Heater ON) The output turns off when temperature is equal or higher than the set value.(Heater OFF)

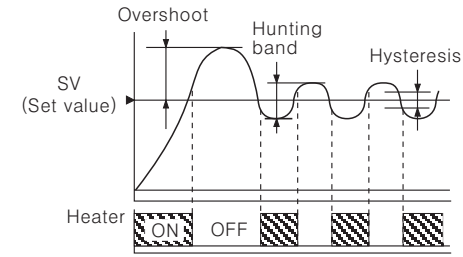

As like above picture, the control value is up and down by set value, it is called Hunting. And Overshoot is occurred at initial point when just power on. If the Hunting and Overshoot is less, it will be a good control.

Double set temperature controller(T4LP)

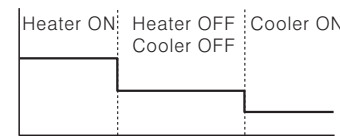

It is able to control a heater and a cooler with 1 piece of double set temperature controller. The 1st(Low set) output is for a heater control and 2nd(Hi set) output is for a cooler control.

Hysteresis

The ON/OFF control has hysteresis due to reduce the chattering or noise affection. Generally make hysteresis bigger for compressor or cooler due to this reason.

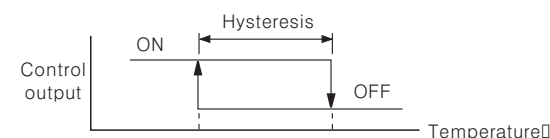

Ex)If temperature range is 0 to 400°C and hysteresis is 0.5%(2°C), therefore when the set value is 300°C, 301°C:OFF and 299°C:ON.

Proportional control

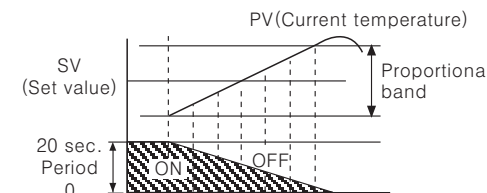

*If the temperature is getting higher, ON time will be shorter.

Pulse output type of ON/OFF such as Relay output or SSR output(Voltage output) are ON/OFF repeatedly with constant cycle. When the PV and SV is the same, the output value will be 50% and ON/OFF time rate is 1:1.

How to select ON/OFF or proportional by plug pin

- Control mode selection by plug pin



Function

- BURN OUT detection function : Make the output OFF when the thermocouple is broken.
- Voltage output : The output is 24VDC ±3V 20mA max for driving external SSR.
- Direct/Reverse operation : Reverse operation is the output ON when the display value is lower than set value, Direct operation is for cooler.
- *This product operates as reverse operation.

Load connection

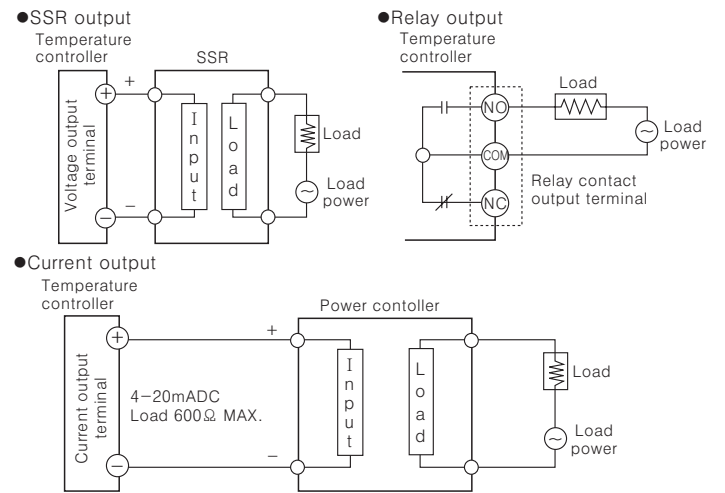

Applications

Food	Packaging machinery, Banding machinery
Plastic	Plastic machinery, Film making system, etc.
Industry	Electric furnace, Auto soldering machine, Drying machine, etc.
Textile	Body press, Textile machine, Sizing machine
Etc.	Cement making machinery

Caution for using

- Installation environment
 - It shall be used indoor
 - Altitude Max. 2000m
 - Pollution Degree 2
 - Installation Category II.
- Please use the terminal(M3.5, Max.7.2mm) when connect the AC power source.
- Please use separated line from high voltage line or power line in order to avoid inductive noise.
- Please install power switch or circuit-breaker in order to cut power supply off.
- The switch or circuit-breaker should be installed near by users.
- Do not use this product as Volt-meter or Ampere-meter, this is a temperature controller.
- Be sure to use compensating wire when extends wire from controller, otherwise the temperature deviation will be occurred at the part where wires are connected each other.
- In case of using RTD sensor, 3wire type must be used. If it needs to extend the line, 3wires must be used with the same thickness as the line. It might cause the deviation of temperature if the resistance of line is different.
- In case of making power line and input signal line close, line filter for noise protection should be installed at power line and input signal line should be shielded.
- Keep away from the high frequency instruments. (High frequency welding machine & sewing machine, big capacitive SCR controller)
- When change the control mode, please apply power after change the mode switch.
- Do not connect power line on No.15, 16, 18 of terminal block for the sensor.

*It may cause malfunction if above instructions are not followed.

Main products

- COUNTER
- TIMER
- TEMPERATURE CONTROLLER
- PANEL METER
- TACHOMETER/ LINE SPEED METER/ PULSE METER
- DISPLAY UNIT
- PROXIMITY SENSOR
- PHOTOELECTRIC SENSOR
- FIBER OPTIC SENSOR
- INTERNATIONAL SALES :
- PRESSURE SENSOR
- ROTARY ENCODER
- SENSOR CONTROLLER
- POWER CONTROLLER
- STEPPING MOTOR & DRIVER & CONTROLLER

Autonics Corporation
http://www.autonics.net

HEAD QUARTER :
41-5, Yongdang-ri, Ungsang-eup, Yangsan-si, Gyeongnam, Korea 626-847
INTERNATIONAL SALES :
512 Ansong B/D, 410-13, Shindorim-dong, Guro-gu, Seoul, Korea 152-070
TEL:82-2-2679-6585 / FAX:82-2-2679-6556
E-mail : sales@autonics.net

NO20030117-EP-KE-03-0065B