



# EMPR



## Electronic motor protection relays

**EMPR** is digital motor protection relay where the MCU (Microprocessor Control Unit) is built-in and features excellent reliability by achieving real-time data processing and high precision.

GMP Series



DMP Series



IMP Series





# G

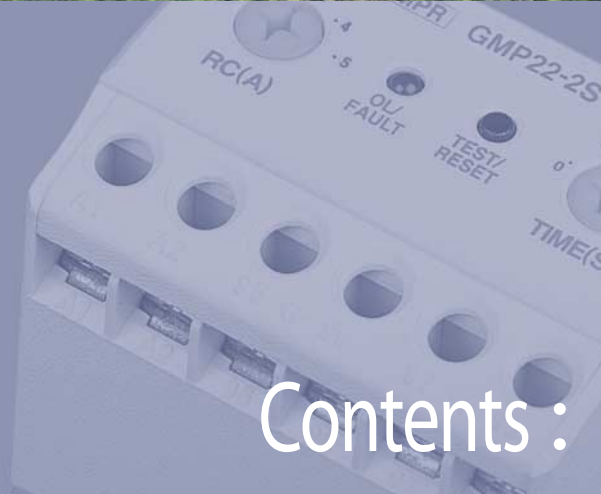

## Contents :

Features .....	G-6
Ordering .....	G-9
Specification .....	G-10
Characteristics .....	G-14
Setting method .....	G-24
Dimensions .....	G-33
Wiring method .....	G-39
Accessories .....	G-42
Direct mounting EMPPR new/old comparative table .....	G-44



**EMPR** replacing thermal overload relay is electronic motor protect relay which is used to protect the low voltage motor and also called as Electronic Overcurrent Relay or an Electronic Overload Relay.

As a digital motor protection relay with MCU EMPR is highly reliable by realization of real-time data processing and, retention confidentiality and also can secure motor safely with various functions such as phase loss, phase reverse, unbalanced, stall, lock, ground fault, short circuit protection depending on the model .

Compact and stylish appearance can be combined with the magnetic contactor and various installation methods make easy design features and manufacture motor control panel.

Especially, EMPR is EMC tested and approved to operate safely without any malfunction caused by electromagnetic wave and surge. Most of the models have received CE Mark and UL certification.



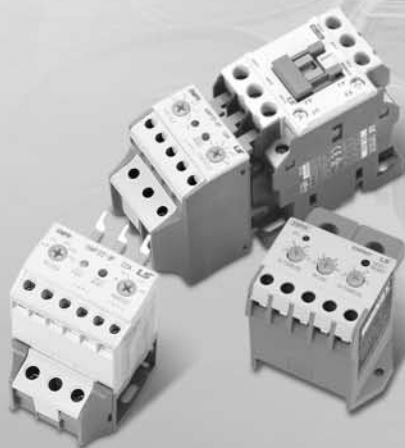

General Motor Protection Relay

### GMP Series

- Various connection & mount
- Inverse or definite time mode
- Ground fault type
- Display the causes of the fault by LED



Digital Motor Protection Relay

### DMP Series

- Ampere meter, Load rate and the causes of fault Display
- Standard, Ground fault and short circuit protection type
- Select the Inverse or definite time modes
- Unit or Extension in one body by cable option
- Option function type (DMP-a)



Intelligent Motor Protection Relay

### IMP Series

- Wide current setting range (0.125~100A)
- Communication support type
- Zero current and residual current sensing
- Save the fault events and operating time setup
- Select the Inverse, thermal inverse or definite time modes
- Unit or Extension in one body by option cable

G  
EMPR/DMPR



# Electronic Motor Protection Relays

# Electronic motor protection relays

## Features

### GMP Series

- Combination with Metasol contactors for compact motor starters

EMPR model	Contactor model
GMP22-2P/3P/3PR	MC-9b, MC-12b, MC-18b, MC-22b
GMP40-2P/3P/3PR	MC-32a, MC-40a

- Broad range of current setting
- Inverse time or definite time characteristics
- Simple operation and trip cause indication via LED
- Various Connection

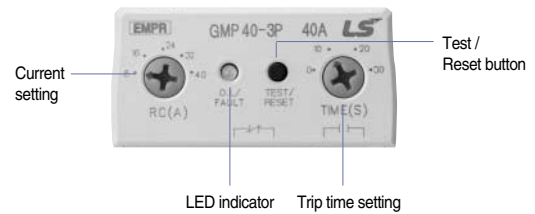
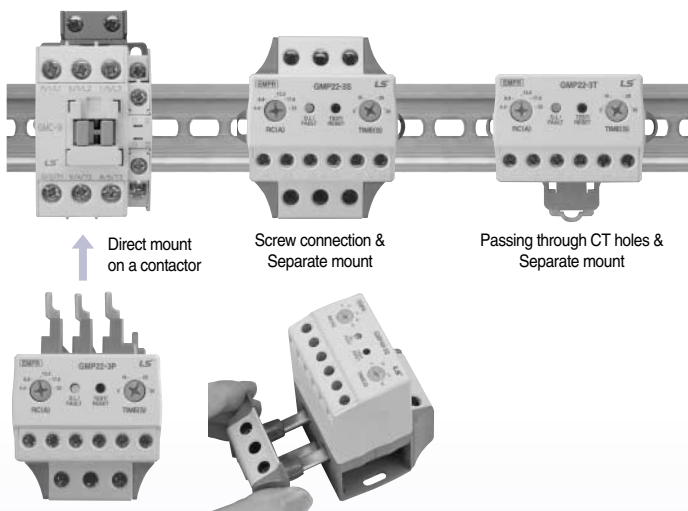

Certification of CE, UL, CCC and S mark



- Various protection functions

Types (GMP-□)	2P, 2T, 2S	3P, 3T, 3S	3PR, 3TR, 3SR	3TN, 3TZ	3TNR, 3TZR
Number of sensors	2CT	3CT			
Overcurrent	■	■	■	■	■
Phase failure	■	■	■	■	■
Lock/Stall	■	■	■	■	■
Phase unbalance		■	■	■	■
Reverse phase			■		■
Ground fault				■	■

- Large current can be applied through additional current transformers
- MCU (Microprocessor Control Unit) built-in
  - excellent reliability by achieving real-time data processing and high precision.
- Store of the last failure cause
  - can be checked by Test/Reset button 2 times.
- Products for ground fault protection
  - detecting of zero phase currents (ZCT used: GMP60-3TZ)
  - detecting of residual currents (ZCT unused: GMP60-3TN)

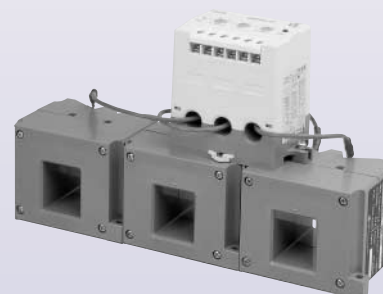

# Features

## DMP Series

- Digital measuring and displaying
  - Display digital ampere-meter
  - Save the causes of the fault and the value
  - Display motor load rate by graph

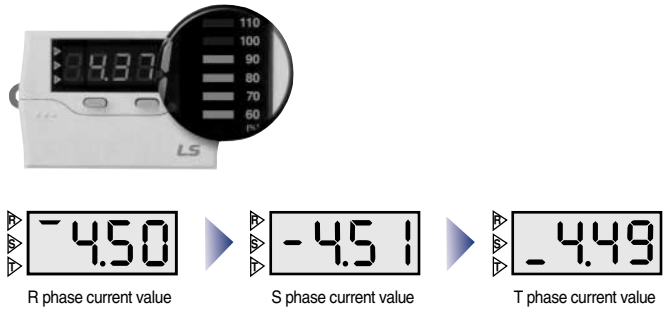
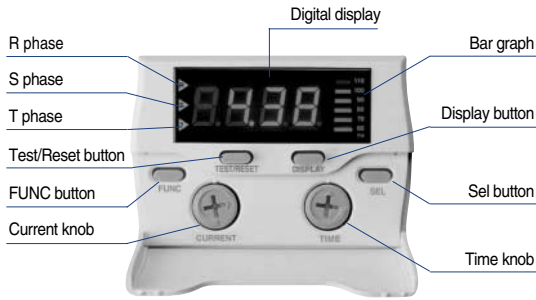

- Convenient structure
  - Install the Unit / Extension type in one body
  - The display part may be separated from the body
  - You can check the values and the causes of the fault without opening the distribution panel door
  - removable terminal block



- Various protection functions

Protection	DMP□-S/Sa	DMP□-SZ/SZa	DMP□-SI	DMP□-T/Ta	DMP□-TZ/TZa	DMP□-TI
<b>Wiring</b>	Screw type			Tunnel type		
<b>Over current</b>	■	■	■	■	■	■
<b>Under current</b>	■	■	■	■	■	■
<b>Stall</b>	■	■	■	■	■	■
<b>Lock</b>	■	■	■	■	■	■
<b>Phase failure</b>	■	■	■	■	■	■
<b>Reverse phase</b>	■	■	■	■	■	■
<b>Phase unbalance</b>	■	■	■	■	■	■
<b>Ground fault</b>		■			■	
<b>Short circuit</b>			■			■

- Trip curve selectable (Inverse/Definite)

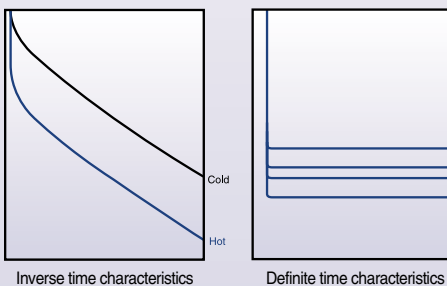

- Applicable to inverter control circuit
  - LS DMPR has high performance under the harmonic noise and can be used in the Inverter control circuit (20~200Hz)
- Optional functions (DMP-a type)
  - Storing up the last fault cause
  - Storing up motor operation hours

# Electronic motor protection relays

## Features

### IMP Series

The EMPR IMP series are optimal solutions for protecting and monitoring motors in complex industrial fields and provide high safety and productivity.



#### Wide Current Setting Range: 0.125~100A for One Model

With the slide S/W, the current setting range can be decided 0.5~10A or 5~100A. According to the CT penetration number, even 0.125A current can be protected. (Wire penetration hole).



#### Communication support type

RS-485 MODBUS communication with various systems. The model with analogue signals (4~20mA) is compatible with transducer systems.



#### Thermal Inverse Time, Inverse Time and Definite Time Modes

According to user's needs, the motor can be protected in the inverse time mode or definite time mode.



#### Wide Ground Fault Sensitivity 30mA~25A

zero current sensing by zero sequence CT.  
zero current sensing by Residual circuit.



#### Date and Total Operating Time Setup

When a fault occurs, its date and time are stored for easy checkup. When the total operation time is over, it is displayed for changing motor bearings or supplying oil.



#### Quick Setup

All settings can be decided quickly on the display.



#### Total Digital Motor Protection Relay with the MCU (Microprocessor Control Unit)

Real-time processing and high precision



#### One-Body Type and Separate Body Type

The display can be attached to the panel front so that current, operation time and settings can be checked without fetching the unit. With the display separated, the motor can be protected.



#### Applicable to Inverter Circuits

Thanks to its good high harmonic noise characteristics, it can be applied to the of inverter control circuits. The available frequency range is 20~200Hz. When the relative harmonic factor is over 30%, a harmonic filter should be installed (However, the ground fault function should be off).



#### Various Reset Functions

Manual, automatic and electric reset functions are provided for customer convenience.



#### Password

Settings are protected with a password.



#### Storage of Fault Events

Up to five fault events can be stored for easy fault history management.



#### 3-Phase Digital Ampere-Meter

3-phase current is displayed every two seconds for motor monitoring.



# Ordering

## GMP Series

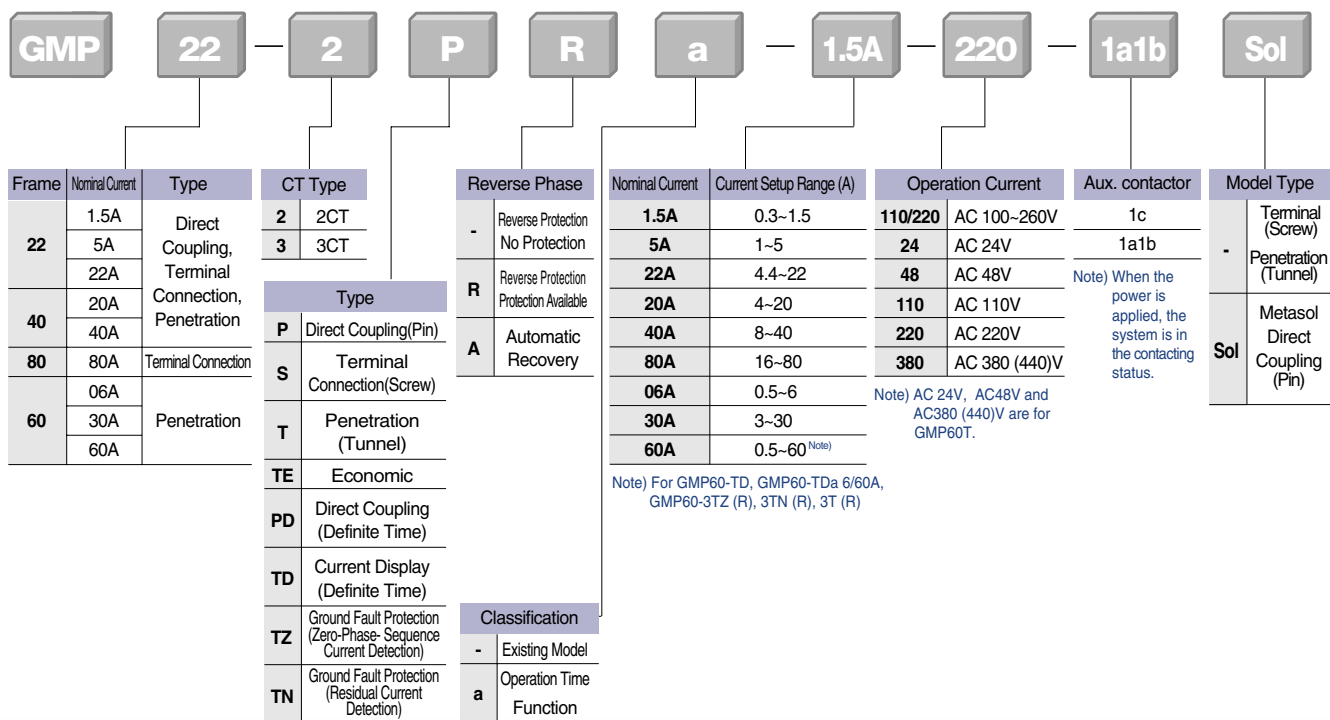

## DMP Series

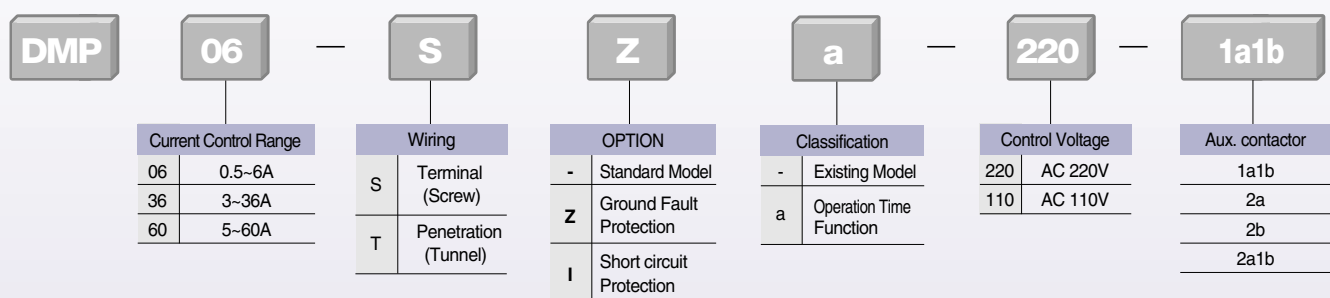

Note) 1. Even the same model has different contact specifications.  
2. When the power is applied, the system is in the contacting status.

## IMP Series

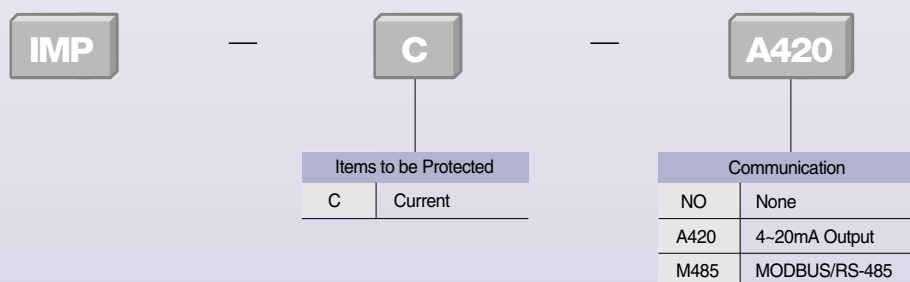

# Electronic motor protection relays

## Specification GMP Series

### Ratings



Model	GMP22-2P/PD (1c)	GMP22-2P(1a1b)	GMP22-3P/3PR	GMP22-2S	GMP22-3S/3SR	GMP22-2T	GMP22-3T/3TR
Type	Pin type			Screw type		Tunnel type	
No. of CT	2CT	2CT	3CT	2CT	3CT	2CT	3CT
Protection	Overcurrent	●	●	●	●	●	●
	Phase failure <sup>Note1)</sup>	●	●	●	●	●	●
	Lock/Stall	●	●	●	●	●	●
	Phase unbalance	—	—	●	—	●	●
	Reverse phase	—	—	●(3PR)	—	●(3SR)	—
Current setting range (A)	0.3~1.5, 1~5, 4.4~22						
Operating time characteristics	Inverse time (GMP22-2PD: Definite time)						
Time setting (sec)	Inverse time	0~30 sec					
	Definite D-time	0.2~60 sec for GMP22-2PD					
		O-time	5sec (Fixed) for GMP22-2PD				
	Reset-time	Manual reset					
Tolerance	Current	±5%					
	Time	±5%(or ±0.5sec)					
Control power	Voltage	AC 110V/220V(±10%)	AC 100~260V				
	Frequency	50/60Hz					
Aux. contact	Contact <sup>Note 3)</sup>	1SPDT (1c)	2SPST (1a1b)				
	Ratings	5A/250VAC Resistive load	3A/250VAC Resistive load				
	Operate	(95 ⇄ 96 Close)	(95 ⇄ 96 Close)	(97 ⇄ 98 Open)			
Insulation resistance	Min 100MΩ at 500Vdc						
Surge endurance (IEC 61000-4-5)	5kV Apply the standard wave						
Fast transient burst (IEC 61000-4-4)	2kV						
Environment	Operation	-25~70°C					
Temperature	Storage	-30~80°C					
	Relative humidity	30~90%RH(No freezing)					
Trip indicator	Red LED	Red/Green LED	Red LED	Red/Green LED	Red LED	Red/Green LED	
Dimension (mm)	W × H × D	44 × 71 × 78	53 × 78 × 87.5	53 × 68 × 87.5		53 × 38 × 87.5	
Mounting type	Direct mount onto a Metasol MC (MC-9b-22b)			Separate mount (Screw or Din-rail) <sup>Note2)</sup>			
Certification	UL, cUL, CE						

Note) 1. When it is 2CT model, only two-phase protection is available

2. The bracket for Din-rail mount is optional

3. When power applied Aux. contact operate

# Specification

## GMP Series

### Ratings

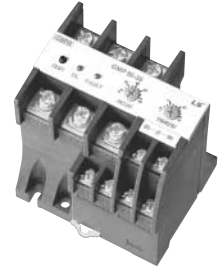

Model		GMP40-2P/PA	GMP40-3P/3PR	GMP40-2S	GMP40-3S/3SR	GMP40-2T	GMP40-3T/3TR	GMP80-2S/SA	GMP80-3S/3SR
Type		Pin type *		Screw type		Tunnel type		Screw type	
No. of CT		2CT	3CT	2CT	3CT	2CT	3CT	2CT	3CT
Protection	Overcurrent	●	●	●	●	●	●	●	●
	Phase failure <sup>Note1)</sup>	●	●	●	●	●	●	●	●
	Lock/Stall	●	●	●	●	●	●	●	●
	Phase unbalance	—	●	—	●	—	●	—	●
	Reverse phase	—	●(3PR)	—	●(3SR)	—	●(3TR)	—	●(3SR)
Current setting range(A)		4~20, 8~40						16~80	
Operating time characteristics		Inverse time characteristics							
Time setting (sec)	Inverse time	0~30 sec							
	Definite D-time	0.2~60 sec (GMP40-2PD)							
		O-time	5sec (Fixed) (GMP40-2PD)						
	Reset time	Manual reset (Auto Reset type : GMP□-A)							
Tolerance	Current	±5%							
	Time	±5% (or±0.5 sec)							
Control power	Voltage	AC 100~260V, 50/60Hz							
Aux. contact	Contact <sup>Note2)</sup>	2SPST (1a1b)							
	Ratings	3A/250VAC Resistive load							
	Operate	(95 ± 96 Close)				(97 ± 98 Open)			
Insulation resistance		Min 100MΩ at 500Vdc							
Surge endurance (IEC 61000-4-5)		5kV Apply the standard wave							
Fast transient burst (IEC 61000-4-4)		2kV							
Environment	Operation	-25~70°C							
	Storage	-30~80°C							
Temperature	Relative humidity	30~90%RH (No freezing)							
Trip indicator		Red LED	Red/Green LED	Red LED	Red/Green LED	Red LED	Red/Green LED	Red LED	2Red LEDs
Dimension(mm)	W × H × D	53 × 78 × 87.5		53 × 68 × 87.5		53 × 38 × 87.5		89 × 77.5 × 97.4	
Mounting type		Direct mount onto a Metasol MC (MC-32a, 40a)		Separate mount (Screw or Din-rail)					
Certification		UL, cUL, CE							

Note) 1. When it is 2CT model, only two-phase protection is available  
 2. When power applied Aux. Contact operate

# Electronic motor protection relays

## Specification GMP Series

### Ratings





Model	GMP60T	GMP60TE GMP60TA	GMP60-TD	GMP60-TDa	GMP60-3T(R)	GMP60-3TZ(R) GMP60-3TN(R)
Type	Tunnel type		Tunnel type		Tunnel type	Tunnel type
No. of CT	2CT		2CT		3CT	3CT
Protection	Overcurrent	●	●	●	●	●
	Phase failure	●	●	●	●	●
	Lock/Stall	●	●	●	●	●
	Phase unbalance	—	—	●	●	●
	Reverse phase	—	—	● (R Type)	● (R Type)	● (R Type)
	Ground fault <sup>Note1)</sup>	—	—	—	—	●
Current setting range (A)	0.5~6, 3~30, 5~60		0.5~60		0.5~60	0.5~60
Operating time characteristics	Definite		Definite		Definite	Definite
Time setting (sec)	D time	0.2~30 sec		1~60 sec	0.2~60 sec	0.2~60 sec
	O time	0.2~30 sec	5 sec (Fixed)	0.5~30 sec	0.2~15 sec	3 sec (Fixed)
	A time (Reset)	—	0.2~120 <sup>Note4)</sup>	—	1~20 min	—
Tolerance	Current ±5% Time ±5% (or±5 sec)					
Control power	Voltage <sup>Note3)</sup>	AC 110V/220 (±10%) <sup>Note3)</sup>		AC 110V or 220V	AC 100V~260V	
	Frequency	50/60Hz				
Aux. contact	Contact <sup>Note2)</sup>	1SPDT (1c)		2SPST (1a1b)		
	Ratings	1A/250VAC Resistive load		3A/250VAC Resistive load		
Insulation resistance	Min 100MΩ at 500Vdc					
Surge endurance (IEC 61000-4-5)	5kV Apply the standard wave					
Fast transient burst (IEC 61000-4-4)	2kV					
Environment	Operation	-25~70°C				
	Storage	-30~80°C				
	Relative humidity	30~90% RH (No freezing)				
Trip indicator	Red LED		7 Segment		Red/Green × 2-Color LED	Red/Green × 2-Color LED, Red LED
Dimension(mm)	W × H × D		72 × 67 × 69		75 × 72.8 × 47	94.6 × 95 × 97
Mounting type	Separate mount (Screw or Din-rail)					
Certification	UL, cUL, CE					

- Note) 1. 3TZ(R): Zero sequence CT type, 3TN(R): Residual circuit  
 2. When power applied the Aux. contact operate  
 3. GMP60T/TE: AC24V, 48V or 380V, 50/60Hz types a option  
 4. GMP60TA: Auto Reset type

# Specification

## DMP/IMP Series

Ratings									
		Model	DMP□-S/SZ/SI	DMP□-Sa/SZa	DMP□-T/TZ/TI	DMP□-Ta/TZa	IMP-C-NO	IMP-C-A420	IMP-C-M485
<b>Wiring</b>		Screw type		Tunnel type		Tunnel type			
<b>Panel mount</b>		Unit or Extension <sup>Note1)</sup>				Unit or Extension			
<b>Operation time</b>		Inverse/Definite				Thermal Inverse/Inverse/Definite			
<b>Protection</b>	<b>Over current</b>	According to the setting time				According to the setting time			
	<b>Phase failure</b>	3 sec				1.5 sec			
	<b>Reverse phase</b>	Within 0.1 sec				Within 0.1 sec			
	<b>Lock/Stall</b>	Within 0.5 sec				Within 0.5 sec			
	<b>Phase unbalance</b>	5 sec				5 sec			
	<b>Under current</b>	3 sec				3 sec			
	<b>Ground fault</b>	Within 0.05~1 sec. (DMP□-Z/Za Model)				Within 0.05~1 sec <sup>Note2)</sup>			
	<b>Short circuit</b>	Within 50ms (DMP□-I Model)				Within 50ms			
<b>Alarm</b>		Variable (60~110% of the setting current)				Variable (60~110% of the setting current)			
<b>Current setting range (A)</b>		6: 0.5~6A, 36: 3~36A, 60: 5~60A				0.5~100			
<b>Time setting (sec)</b>	<b>Definite</b>	<b>D time</b>	0~60 sec				1~200 sec		
		<b>O time</b>	0~30 sec				1~60 sec		
	<b>Inverse time</b>	0~60 sec				1~60 sec			
	<b>A time (Reset)</b>	Manual reset				Manual reset/Automatic			
<b>Tolerance</b>	<b>Current</b>	±5%				±5%			
	<b>Time</b>	±5% (or ±0.5 sec)				±5% (or ±0.5 sec)			
<b>Operating power</b>	<b>Voltage</b>	AC 110V or 220V, 50/60Hz				AC/DC 85~245V, 50/60Hz			
<b>Aux. contact</b>		2a, 2b, 1a1b				OL: 1a1b, AL: 1a			
<b>Insulation resistance</b>		Over DC 500V 100MΩ				Over DC 500V 100MΩ			
<b>Surge impulse voltage (IEC 61000-4-5)</b>		5kV				5kV			
<b>Fast transient burst (IEC 61000-4-4)</b>		2kV				2kV			
<b>Environment</b>	<b>Operation</b>	-25~70°C				-25~70°C			
	<b>Storage</b>	-30~80°C				-30~80°C			
<b>Temperature</b>		Relative humidity		30~90% RH (No freezing)		30~90% RH (No freezing)			
<b>Display</b>	<b>7-Segment</b>	3 phase current, cause of a fault				3 phase current, cause of a fault			
	<b>Bar-Graph</b>	60~110% of real load current				60~110% of real load current			
<b>Mounting type</b>		35mm Din-rail/Panel				35mm Din-rail/Panel			
<b>Certification</b>		UL, cUL, CE							

Note) 1. In extension type, the digital EMPR is calibrated with combining the display part and main body so, please cautious not to combine the display part and main body with different part No.  
 2. Zero current sensing by zero sequence CT and Residual circuit.

# Electronic motor protection relays

## Inverse time characteristics

### GMP22/40 Type



#### Description

- Wide and adjustable current range
- Adjustable trip time (trip class 5-30)
- Designed suitable for use with contactors
  - Directly mountable on the Metasol contactors (Pin type)
  - Separate mount versions are also available
  - Separately mountable on 35mm DIN rail or with screws
- 1NO+1NC trip contacts
- Manual reset as standard (Automatic reset optional)

#### Front face configuration

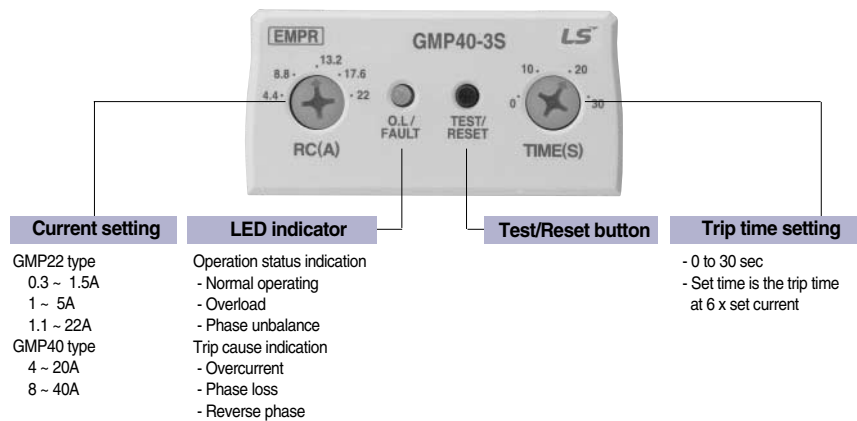

**Certificate**  
CE, ULcUL

#### Extended protective functions

Types (GMP22/40-□)	-2P, -2T, -2S	-3P, -3T, -3S	-3PR, -3TR, -3SR
Number of sensors	2CT	3CT	3CT
Functions	Overcurrent	✓	✓
	Phase failure	✓	✓
	Locked rotor	✓	✓
	Phase unbalance		✓
	Reverse phase		✓

#### Technical information

Relay control voltage	100 to 260V AC 50/60Hz
Auxiliary contact	3A/250VAC at resistive load
	1NO (97-98) + 1NC (95-96)
Setting tolerance	Current ± 5%
	Time ± 5% (or ± 0.5sec)
Insulation resistance	Min 100MΩ at 500V DC
Impulse withstand voltage	5kV (IEC 61000-4-5)
Fast transient burst	2kV (IEC 61000-4-4)
Ambient temperature	-25 to 70°C for operation
	-30 to 80°C for storage
Humidity	30 to 90% RH

# Inverse time characteristics

## GMP22/40 Type

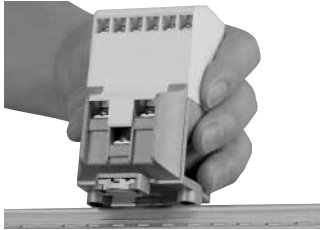

To mount on 35mm DIN rail

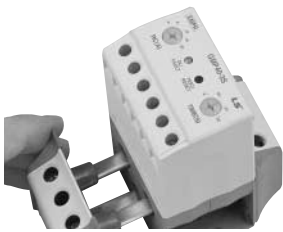

Cable connection part can be modified between screw connection and passing CT hole

### Selection (GMP22 Type)

Mount/Connection	Sensor	Setting range	Catalog No.	
<b>Directly on a contactor</b>	2-sensor (2 CT)	0.3 - 1.5A	GMP22 - 2P · 1.5	
		1 - 5A	GMP22 - 2P · 5	
		4.4 - 22A	GMP22 - 2P · 22	
	3-sensor (3 CT)	0.3 - 1.5A	GMP22 - 3P · 1.5	
		1 - 5A	GMP22 - 3P · 5	
		4.4 - 22A	GMP22 - 3P · 22	
	3-sensor Reverse phase detection	0.3 - 1.5A	GMP22 - 3PR · 1.5	
		1 - 5A	GMP22 - 3PR · 5	
		4.4 - 22A	GMP22 - 3PR · 22	
<b>Separate mount</b>	2-sensor (2 CT)	0.3 - 1.5A	GMP22 - 2S · 1.5	
		1 - 5A	GMP22 - 2S · 5	
		4.4 - 22A	GMP22 - 2S · 22	
<b>Cable connection with a screw</b>	3-sensor (3 CT)	0.3 - 1.5A	GMP22 - 3S · 1.5	
		1 - 5A	GMP22 - 3S · 5	
		4.4 - 22A	GMP22 - 3S · 22	
	3-sensor Reverse phase detection	0.3 - 1.5A	GMP22 - 3SR · 1.5	
		1 - 5A	GMP22 - 3SR · 5	
		4.4 - 22A	GMP22 - 3SR · 22	
	<b>Separate mount</b>	2-sensor (2 CT)	0.3 - 1.5A	GMP22 - 2T · 1.5
			1 - 5A	GMP22 - 2T · 5
			4.4 - 22A	GMP22 - 2T · 22
<b>Connection without a screw - cables pass through CT holes</b>	3-sensor (3 CT)	0.3 - 1.5A	GMP22 - 3T · 1.5	
		1 - 5A	GMP22 - 3T · 5	
		4.4 - 22A	GMP22 - 3T · 22	
	3-sensor Reverse phase detection	0.3 - 1.5A	GMP22 - 3TR · 1.5	
		1 - 5A	GMP22 - 3TR · 5	
		4.4 - 22A	GMP22 - 3TR · 22	

### Selection (GMP40 Type)

Mount/Connection	Sensor	Setting range	Catalog No.
<b>Directly on a contactor</b>	2-sensor (2 CT)	4 - 20A	GMP40-2P · 20
		8 - 40A	GMP40-2P · 40
	3-sensor (3 CT)	4 - 20A	GMP40-3P · 20
		8 - 40A	GMP40-3P · 40
	3-sensor Reverse phase detection	4 - 20A	GMP40-3PR · 20
		8 - 40A	GMP40-3PR · 40
<b>Separate mount</b>	2-sensor (2 CT)	4 - 20A	GMP40-2S · 20
		8 - 40A	GMP40-2S · 40
		<b>Cable connection with a screw</b>	3-sensor (3 CT)
8 - 40A	GMP40-3S · 40		
3-sensor Reverse phase detection	4 - 20A		
	8 - 40A	GMP40-3SR · 40	
	<b>Separate mount</b>	2-sensor (2 CT)	4 - 20A
8 - 40A			GMP40-2T · 40
<b>Connection without a screw - cables pass through CT holes</b>			3-sensor (3 CT)
	8 - 40A	GMP40-3T · 40	
	3-sensor Reverse phase detection	4 - 20A	
8 - 40A		GMP40-3TR · 40	

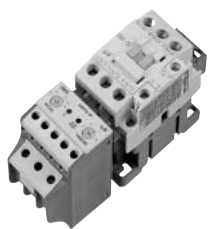

# Electronic motor protection relays

## Definite time characteristics

### GMP60-T(E) Type



### Description

- Small size, economical
- Delay time setting in starting and operation
- Over current, phase failure protection
- Definite time characteristics
- Wide current setting range
- Screw or Din-rail mounting

### Extended protective functions

Types		GMP60-T	GMP60-TE	GMP60-TA
Number of sensors		2CT	2CT	2CT
Functions	Overcurrent	✓	✓	✓
	Phase failure <sup>Note1)</sup>	✓	✓	✓
	Locked rotor	✓	✓	✓
	Auto reset			✓

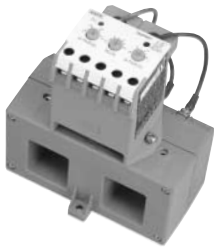

Large current over 60A can be applied through additional current transformers

### Ratings (Tunnel type)

Model		GMP-60T	GMP-60TE	GMP-60TA
Type		Tunnel type		
No. of CT		2		
Current setting range (A)		0.5~6, 3~30, 5~60		
Operating time characteristics		Definite time characteristics		
Time setting (sec)	Starting time	0.2~30		
	Operating time	0.2~15	5	5
	Reset time	Manual reset		0.2~120
Allowable error	Current	±5%		
	Time	±5% (or ±0.5 sec)		
Control power	Voltage	180~260V (AC 24V, 48V, 110V / 440V) <sup>Note2)</sup>		
	Frequency	50 / 60Hz		
Aux. s/w	Contact <sup>Note3)</sup>	1SPDT (1c)		
	Ratings	5A 250Vac, resistive load		
	Operation	95 † 96close		
Insulation resistance		Min. 50 MΩ at 500Vdc		
Surge insurance (IEC 61000-4-5)		5kV		
Fast transient burst (IEC 61000-4-4)		2kV		
Environment	Operation	-25~70°C		
	Storage	-50~80°C		
Relative humidity		46~85 RH (No freezing)		
Trip indicator		LED		
Dimension (mm) W × H × D		72 × 63 × 69		
Mounting type		Separate mount (Screw & Din-rail)		
Certification		UL, cUL, CE		

Note) 1. Under phase failure condition over current flows. The EMPR tripped if it is over the setting over current  
 2. ( ) are optional specifications  
 3. When power applied the Aux. contact operate

### Tunnel type EMPR protects the current under 0.1A

If we increase the number of times of a wire pass through the CT (Tunnel), the EMPR can detect the lower current

No. of times to pass through	Current setting range
1	0.5~6
2	0.25~3
3	0.17~2
4	0.12~1.5



# Ampere meter function

## GMP60-TD(a) Type



### Description

- Definite time characteristics
- Delay time setting in starting and operation
- Over current, phase failure protection
- Definite time characteristics
- Wide current setting range
- Screw or Din-rail mounting
- Display the causes of the fault and the values

### Extended protective functions

Types		GMP60-TD	GMP60-TDa
Number of sensors		2CT	2CT
Functions	Overcurrent	✓	✓
	Phase failure <small>Note1)</small>	✓	✓
	Locked rotor	✓	✓
	Under current		✓
	Auto reset		✓

\* Only two-phase protection is available.

### Ratings (Tunnel type)

Model		GMP60-TD	GMP60-TDa
Type		Tunnel type	
No. of CT		2	
Current setting range (A)		0.5~60	
Operating time characteristics		Definite time characteristics	
Time setting (sec)	Delay time	1~60	
	Operating time	0.5~30	
	Reset time	Manual reset	1~20min
Allowable error	Current	±5%	
	Time	±5% (or ±0.5 sec)	
Control power	Voltage	AC 110/220V	
	Frequency	50 / 60Hz	
Aux. s/w	Contact <small>Note2)</small>	2SPST (1a1b)	
	Ratings	5A 250Vac, resistive load	
	Operation	95 1/2 96close 97 1/2 98open	
Insulation resistance		Min. 50MΩ at 500Vdc	
Surge insurance (IEC 61000-4-5)		5kV	
Fast transient burst (IEC 61000-4-4)		2kV	
Environment Temperature	Operation	-25~70°C	
	Storage	-50~80°C	
Relative humidity		46~85 RH (No freezing)	
Trip indicator		7-Segment	
Dimension (mm) W × H × D		72 × 63 × 69	
Mounting type		Separate mount (Screw & Din-rail)	
Certification		UL, cUL, CE	

Note) 1. Under phase failure condition over current flows. The EMPR tripped if it is over the setting over current

2. When power applied the Aux. contact operate

### Tunnel type EMPR protects the current under 0.1A

If we increase the number of times of a wire pass through the CT (Tunnel), the EMPR can detect the lower current

No. of times to pass through	Current setting range	Current Ratio
1	0.5~6	1
2	0.25~3	0.5
4	0.12~1.5	0.25

# Electronic motor protection relays

## Definite time characteristics with 3CT

### GMP60-3T(R) Type



GMP60-3T  
GMP60-3TR

#### Description

- Cable connecting through CT holes (option: with screw)
- Auxiliary contact: 2SPST (1a1b at energization)
- Wide and adjustable current range (0.5~60A)
- D-time: 0.2~60 sec. / O-time: 0.2~15 sec.
- Control voltage: AC100~245V 50/60Hz
- Manual(electrical) reset as standard
- Applicable to inverter at the secondary circuit (except GMP60-3TR)

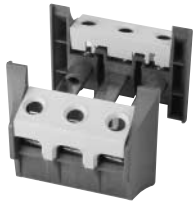

Terminal Lug

#### Extended protective functions

Types		GMP60-3T	GMP60-3TR
Number of sensors		3CT	3CT
Protective functions	Overcurrent	✓	✓
	Phase failure	✓	✓
	Locked rotor	✓	✓
	Phase unbalance	✓	✓
	Reverse phase		✓
Storing the last fault cause		✓	✓

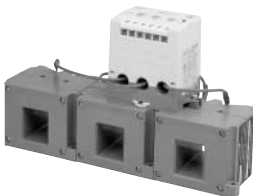

Large current over 60A can be applied through additional current transformers

#### Selection

Mount/Connection	Optional function	Setting range	Catalog No.
<ul style="list-style-type: none"> <li>• Separate mount</li> <li>• Cable Connection through CT holes</li> </ul>	None	0.5 - 60A	GMP60-3T
	Reverse phase	0.5 - 60A	GMP60-3TR

#### Technical information

Mounting	On 35mm rail or panel with screws
Setting tolerance	Current $\pm 5\%$
	Time $\pm 5\%$ (or $\pm 0.5\text{sec}$ )
Frequency	50/60Hz
Auxiliary contact rating	5A/250VAC at resistive load
Insulation resistance	Min 100M $\Omega$ at 500V DC
Surge insurance	5kV (IEC 61000-4-5)
Fast transient burst	2kV (IEC 61000-4-4)
Ambient temperature	-25 to 70°C for operation
	-30 to 80°C for storage
Humidity	30 to 90% RH
Operating indication	Red/Green 2-color LED, Red LED
Standard	UL508, IEC60947-1

# For ground fault current protection

## GMP60-3TZ(R), 3TN(R) Type



GMP60-3TZ, 3TZR  
GMP60-3TN, 3TNR



Terminal Lug

### Description

- Cable connecting through CT holes
- Auxiliary contact: 2SPST (1a1b at energization)
- Wide and adjustable current range (0.5~60A)
- Definite time characteristics  
D-time: 0.2~60sec. / O-time: 3sec.
- With 3 sensors (CT)
- Control voltage: AC100~245V (50/60Hz)

### Extended protective functions

Types		GMP60-3TZ, 3TN	GMP60-3TZR, 3TNR
Number of sensors		3CT	3CT
Protective functions	Overcurrent	✓	✓
	Phase failure	✓	✓
	Ground fault	✓	✓
	Locked rotor	✓	✓
	Phase unbalance	✓	✓
	Reverse phase	✓	✓
Storing the last fault cause		✓	✓

### Selection

Mount/Connection	Ground fault current	Optional function	Setting range	Catalog No.
• Separate mount	Zero phase current (0.1~2.5A)	None	0.5 - 60A	GMP60-3TZ
		Reverse phase	0.5 - 60A	GMP60-3TZR
• Cable Connection through CT holes	*ZCT required  Residual current (0.5~6A)	None	0.5 - 60A	GMP60-3TN
		Reverse phase	0.5 - 60A	GMP60-3TNR

Note) Use ZCT for EMPR, 100mA/40 ~ 55mV

### Technical information

Mounting	On 35mm rail or panel with screws
Setting tolerance	Current $\pm 5\%$
	Time $\pm 5\%$ (or $\pm 0.5\text{sec}$ )
Frequency	50/60Hz
Auxiliary contact rating	5A/250VAC at resistive load
Insulation resistance	Min 100M $\Omega$ at 500V DC
Surge insurance	5kV (IEC 61000-4-5)
Fast transient burst	2kV (IEC 61000-4-4)
Ambient temperature	-25 to 70°C for operation
	-30 to 80°C for storage
Humidity	30 to 90% RH
Operating indication	Red/Green 2-color LED, Red LED
Standard	IEC 61000, KEMC 1120

# Electronic motor protection relays

## Inverse time characteristics

### GMP80 Type

#### Description

- Wide and adjustable current range
- Adjustable trip time (trip class 5-30)
- Separately mountable on 35mm DIN rail or with screws
- 1NO+1NC trip contacts
- Manual reset as standard (Automatic reset optional: GMP80-2SA)



#### Front face configuration

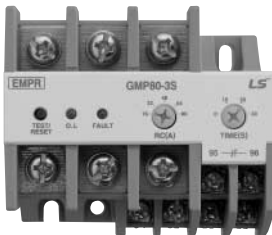
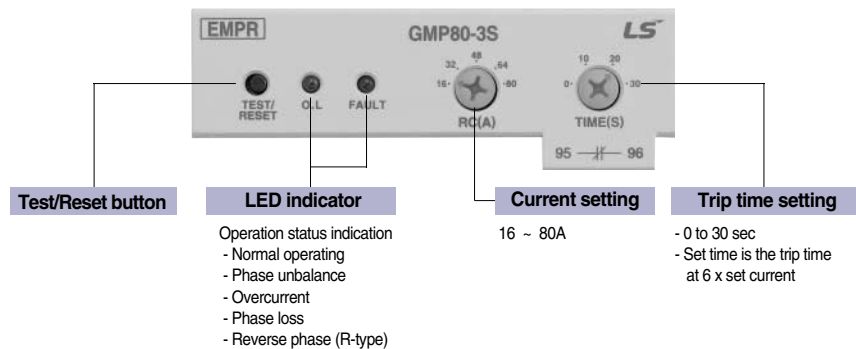

#### Extended protective functions

Types (GMP80-□)	2S	2SA	3S	3SR
<b>Number of sensors</b>	2CT	2CT	3CT	3CT
<b>Functions</b>	Overcurrent	✓	✓	✓
	Phase loss	✓	✓	✓
	Locked rotor	✓	✓	✓
	Phase unbalance			✓
	Reverse phase			✓
	Auto reset		✓	

#### Selection

Mount/Connection	Sensor	Setting range	Catalog No.
Separate mount	2-sensor	16 - 80A	GMP80-2S
	(2 CT)		
Cable connection with a screw	3-sensor	16 - 80A	GMP80-3S
	(3 CT)		
	3-sensor Reverse phase detection	16 - 80A	GMP80-3SR

#### Technical information

<b>Relay control voltage</b>	100 to 260V AC 50/60Hz
<b>Auxiliary contact</b>	3A/250VAC at resistive load
	1NO (97-98) + 1NC (95-96) (When power applied)
<b>Setting tolerance</b>	Current ± 5%
	Time ± 5% (or ±0.5sec)
<b>Insulation resistance</b>	Min 100MΩ at 500V DC
<b>Surge insurance</b>	5kV (IEC 61000-4-5)
<b>Fast transient burst</b>	2kV (IEC 61000-4-4)
<b>Ambient temperature</b>	-25 to 70°C for operation
	-30 to 80°C for storage
<b>Humidity</b>	30 to 90% RH

**Certificate**  
CE, ULcUL

# Characteristics DMP Series

## DMP-S(a)/SZ(a)/SI Type



- Unit type or extension type is available
  - Extension type: Remotely mounts the display unit on the panel surface
- Ampere meter function: current and setting value by press the display button
- Select the inverse time or definite time
- Display the causes of the fault and the values
- Load ratio is displayed up to setting current

### Protect function

<b>Over current</b>	Depend on setting time	Selectable the inverse/definite
<b>Phase failure</b>	Within 3seconds	Over 70% of the rate of unbalance
<b>Phase unbalance</b>	Within 5seconds	Over 50% of the rate of unbalance
<b>Reverse phase</b>	Within 0.1seconds	Function enable
<b>Stall</b>	Within 5seconds	Over 180% of the setting current
<b>Lock</b>	Within 0.5seconds	Setting 200~900% of rated current
<b>Under current</b>	Within 3seconds	Setting 30~70% of rated current

Note) Lock protection is operated after setting D-time in case of definite time type



Extension type (with cable)

### Function selection

FUNC	Sel	Description
<b>1. CHA</b>	Inv/dEF	Operating characteristics setting (Inverse/definite time type)
<b>2. dEF</b> <sup>Note1)</sup>	0~30 (S)	Setting the operating time (In definite type)
<b>3. r.P</b>	oFF/on	Reverse phase enable
<b>4. Und</b>	oFF/30~70 (%)	Under current enable and setting
<b>5. Alt</b>	oFF/60~110 (%)	Alerting enable and setting
<b>6. Stl</b>	oFF/on	Stall enable
<b>7. Loc</b>	oFF/200~900 (%)	Lock enable and setting
<b>8. Ct</b>	1~120	CT ratio setting
<b>9. P.F</b>	on/oFF	Phase fault enable
<b>b. StA</b> <sup>Note2)</sup>	0~120	Operating time setting by month
<b>c. StH</b>	10~730	Operating time setting by hour
<b>d. tAH</b>	A000,000.0	Displaying total operating time (month, hour)
<b>E. rAH</b>	A000,000.0	Displaying operating time (month, hour)
<b>Sto</b>	Sto	Store

Note) 1. **2.dEF** is only displayed when **dEF** is selected in a **1.CHA** mode  
 2. Functions for b to e are available for only Sa & SZa type.

### Ratings

Model	DMP□-S/Sa		DMP□-SZ/SZa/SI
<b>Type</b>	<b>Wiring method</b>		Screw
	<b>Panel mount</b>		Unit or Extension
<b>Operating characteristics</b>	Inverse/definite type		
<b>Alerting function</b>	Variable between 60 and 110%		
<b>Current range (A)</b>	06: 0.5~6, 36: 3~36, 60: 5~60		
<b>Setting time</b>	<b>Definite</b>	<b>Delay (D-T)</b>	0~60seconds
		<b>Operating (O-T)</b>	0~30seconds
	<b>Inverse</b>		0~60seconds
<b>Reset type</b>	Manual reset		
<b>Operating voltage</b>	<b>Voltage</b>		AC 110V or AC 220V
	<b>Frequency</b>		50/60Hz
<b>Aux. contacts</b>	<b>OL</b>	<b>2-SPST (95~98)</b>	3A/250Vac resistive load
	<b>AL</b>	<b>SPST (07-08)</b>	3A/250Vac resistive load
<b>Indicate</b>	<b>7-segment</b>		3-phase current value, fault cause
	<b>Bar-LED arrays</b>		Load ratio (60~110%)
<b>Mounting</b>	35mm Din-rail/Panel		
<b>Certification</b>	UL, cUL, CE		

# Electronic motor protection relays

## Characteristics DMP Series

### DMP-T(a)/TZ(a)/TI Type

- Unit type or extension type is available
  - Extension type: Remotely mounts the display unit on the panel surface
- Ampere meter function: current and setting value by press the display button
- Select the inverse time or definite time
- Display the causes of the fault and the values
- Ground fault protect function is added



Extension type (with cable)

### Protect function

Over current	Depend on setting time	Selectable the inverse/definite
Phase failure	Within 3seconds	Over 70% of the rate of unbalance
Phase unbalance	Within 5seconds	Over 50% of the rate of unbalance
Reverse phase	Within 0.1seconds	Function enable
Stall	Within 5seconds	Over 180% of the setting current
Lock	Within 0.5seconds	Setting 200~900% of rated current
Under current	Within 3seconds	Setting 30~70% of rated current
Ground fault <sup>Note)</sup>	Selectable 0.05~1.0seconds	Grounded current setting by dip s/w (100~2500mA)

Note) Lock protection is operated after setting D-time in case of definite time type

### Function selection

FUNC	Sel	Description
1. CHA	Inv/dEF	Operating characteristics setting (Inverse/definite time type)
2. dEF <sup>Note1)</sup>	0~30 (S)	Setting the operating time (In definite type)
3. r.P	oFF/on	Reverse phase enable
4. Und	oFF/30~70 (%)	Under current enable and setting
5. g-F	oFF/0.05~1.0 (S)	Ground fault enable and setting
6. Stl	oFF/on	Stall enable
7. Loc	oFF/200~900 (%)	Lock enable and setting
8. Ct	1~120	CT ratio setting
9. P.F	on/oFF	Phase fault enable
A. gFd <sup>Note2)</sup>	oFF/on	Setting delay of ground fault
b. StA	0~120	Operating time setting by month
c. StH	10~730	Operating time setting by hour
d. tAH	A000,000.0	Displaying total operating time (month, hour)
E. rAH	A000,000.0	Displaying operating time (month, hour)
Sto	Sto	Store

Note) 1. [2.dEF] is only displayed when [dEF] is selected in a [1.CHA] mode

2. Functions for b to e are available for only SZa & TZa type.

3. Ground fault sensitive current selection: TZa type

### Ratings

Model	DMP□-T/Ta	DMP□-TZ/TZa/TI
Type	Tunnel	
Wiring method	Unit or Extension	
Operating characteristics	Inverse/definite type	
Alerting function	Variable between 60 and 110%	
Current range (A)	06: 0.5~6, 36: 3~36, 60: 5~60	
Setting time	Definite	Delay (D-T) Operating (O-T)
	Inverse	0~60seconds 0~30seconds 0~60seconds
	Reset type	Manual reset
Operating voltage	AC 110V or AC 220V	
Frequency	50/60Hz	
ZCT input (07-08)	200mA/110mV (ZCT) [30 ϕ, 50 ϕ, 65 ϕ, 80 ϕ]	
Aux. contacts (2a, 2b, 1a1b)	OL, GR 2-SPST (95-98)	
Indicate	3A/250Vac resistive load	
7-segment	3-phase current value, fault cause	
Bar-LED arrays	Load ratio (60~110%)	
Mounting	35mm Din-rail/Panel	

# Characteristics IMP Series

## IMP-C Type



Extension type (with cable)

- MODBUS RS-485 Communication or 4~20mA analogue output
- 3 phase ampere meter function: Check the 3 phase current and setting value by press the display button
- Select the Thermal inverse/inverse time or definite time
- Easy to operate: Set the most function by the operation button and knob
- Display the causes of the fault and the values
- Adjustable wide current range (0.5~100A)

### Protect function

Over current	Depend on setting time	Selectable the inverse/definite
Phase failure	Within 1.5seconds	Over 70% of the rate of unbalance
Phase unbalance	Within 3seconds	10~70% of the rate of unbalance
Reverse phase	Within 0.1seconds	Function enable
Stall	Within 3seconds	setting 150~500% of rated current
Lock <sup>Note1)</sup>	Within 0.5seconds	Setting 200~800% of rated current
Under current	Within 3seconds	Setting 30~90% of rated current
Ground fault <sup>Note2)</sup>	Selectable 0.05, 0.1~1.0seconds	gF: 0.03/0.05/0.1~3A gn: 20~500% of the FLC min

Note) 1. Lock protection is operated after setting D-time in case of definite time selected.  
2. [12. gF] Zero sequence CT, [13. gn] Residual circuit sensing.

### Setting Menu (A Group)

Menu	Setting Value	Item	Default Value
1.CHA	dEF/th/n-th	Operation Characteristics (Definite Time / Heat Accumulation Inverse Time /Inverse Time)	n-th
2.O-t	1~60s	Operation Time (sec)	60
3.d-t	1~200s	Operation Delay (sec)	In chase of dEF
4.r-C	0.5~10A/5~100A	Rated Current	Max.
5.Ctr	0.25, 0.5, 1~200	CT Ratio (4 times, twice, once)	1
6.Loc	OFF, 200~800%	Lock Protection (sec)	OFF
7.StL	OFF, 150~500%	Stall Protection (sec)	OFF
8.P-F	OFF/On	Open Phase	OFF
9.P-U	OFF, 10~70%	Unbalance Protection (%)	OFF
10.rP	OFF/On	Reverse Phase	OFF
11.UC	OFF, 30~90%	Low Current Protection (%)	OFF
12.gF	OFF, 0.03, 0.05/0.1~3A	Ground Fault Operation Current (Zero-Phase-Sequence Current) (A)	OFF
13.gn	OFF, 20~500% (FLCmin)	Ground Fault Operation Current (Post-Arc Current) (FLCmin)	OFF
14.gt	0.05, 0.1~1.0s	Ground Fault Operation Time (Current)	-
15.gd	On/OFF	Ground Fault Delay During Start	ON
16.IC	OFF, 500~1000%	Instantaneous Protection (%)	OFF
17.lo	AL/TrIP	Instantaneous Warning/Operation	TriP

Note) 1. When the rated current S/W is 100A, the CT ratio is not displayed.  
2. Some menus are not displayed if relevant functions are not available.

### Ratings

Model	IMP-C-NO, M485, A420	
Type	Wiring method	Tunnel
	Panel mount	Unit or Extension
Operating characteristics		defin/TH-Inv./n-TH
Alerting function		Variable between 60 and 110%
Current range (A)		0.5~100
Setting time	Definite	1~200seconds
	Delay (D-T)	0~30seconds
	Operating (O-T)	0~60seconds
	Inverse/TH-Inverse time	0~60seconds
	Reset type	Manual reset
Operating	voltage	AC 85~245V, 50/60Hz
	ZCT input (07-08)	200mA/110mV (ZCT) [30 ϕ , 50 ϕ , 65 ϕ , 80 ϕ ]
Aux. contacts (2a, 2b, 1a1b)	OL, GR 2-SPST (95~98)	5A/250Vac resistive load
Indicate	7-segment	3-phase current value, fault cause 5point
	Bar-LED arrays	Load ratio (60~110%)
Mounting		35mm Din-rail/Panel
Communication		A420: Analog, M485: Modbus
Certification		CE

### Setting Menu (B Group)

Menu	Setting Value	Item	Default Value
1.E-r	On/OFF	Electric Recovery	On
2.A-r	OFF, 1~20 min	Automatic Recovery (Minute)	OFF
3.r-t	Hour/Minute	Operation Time	Time Check
4.Srt	OFF, 1~8760Hour	Operation Time Setup (Hour)	-
5.s-d	2009/01.01/00:00	YY/MM/DD/ HH:MM	-
6.Trt	Day/hour:minute	Total Operation Time	Time Check
A.t-d	0.5~10/5~100A	20mA Output Setup	A420
A.Adr	1~247	Communication Address	M485 Model
b.bps	96/192/384	Communication Speed	
c.S-P	On/OFF	SWAP	

Note) 1. When the power is supplied first or is resupplied after a power failure, must set up the date (5.S-d).  
2. Automatic recovery is only possible in case of an excess current trip.

# Electronic motor protection relays

## Setting method

### GMP Series Inverse time

#### 1. Check the rated voltage and apply the control power to A1 and A2 terminal

#### 2. Check the TEST/RESET button

- 1) When you press the 'Test/Reset' button, the O.L LED is turned on and the EMPR is tripped
- 2) When you press the 'Test/Reset' button under the EMPR is tripped, the O.L LED is turned off and the EMPR is reset
- 3) Auto reset function: When it is tripped by the over current, it is reset after 1 Min.(Optional)

#### 3. Set the operating time

The operating time is set on the base of 600% of the rated current in the characteristic curve

- 1) Set the operating time by considering the operating time and start current according to the types of the load
- 2) If the time knob is set to 10sec, the EMPR is tripped when the start current (600% of the rated current) is applied for 10sec

Caution) The EMPR with inverse time characteristics can be tripped to protect the motor when the motor is started a few times continuously  
When a motor is frequently changing the rotating direction (forward and reverse), set the operating time longer For the crane and hoist use, select the EMPR with definite time characteristics

#### 4. Set the operating current

Set the current by considering the rated current of a motor to protect from the over current

- 1) Check the rated current of a motor is within the current setting range of an EMPR
- 2) Set the 'RC' (Rated current) knob to the maximum value and then start a motor
- 3) Under normal motor operation, rotate the 'RC' knob to the counterclockwise until the 'O.L' LED flickers The current at this point in the 100% current rating under real load
- 4) At this point, rotate the 'RC' knob to the clockwise until the 'O.L' LED turned off.  
Ex) When the 'O.L' LED flickering at 20A, the setting current will be 22A(=20x1.1)

Note) The brackets for connection is offered standard

#### 5. Check status of operation by LED

- 1) In case of overcurrent  
If there will be an overcurrent during motor operation, the red color of LED will flicker at 0.4 second intervals. After tripping because of overcurrent, the red color of LED will light up.
- 2) In case of phase failure  
If there will be a phase failure in three phase load, it will be tripped within 3 seconds.  
Note) 2CT EMPR can protect motor from R or T phase failure.
- 3) In case of phase unbalance  
If phase unbalance rate is over 50%, FAULT LED will flicker 0.4 second intervals.
- 4) In case of Reverse phase  
Red & green color LED will flicker alternately.

		Condition	LED Status	LED Diagram	Remark
Operating status		Normal	LED OFF		
		Over current	0.4 Second intervals		
		Phase unbalance (30~50%)	0.4 Second intervals		GMP 80-3S/3SR model, only red color LED will flicker.
Tripped status		Over current	O.L LED light up		
	Phase failure (3CT)	R	1 time for 3 seconds		GMP 80-3S/3SR model, O.L LED will light up and also FAULT LED will flicker.
		S	2 time for 3 seconds		
		T	2 time for 3 seconds		
		Phase failure (2CT)	Red LED light up for 0.9 sec LED goes off for 0.1 sec		
	Reverse phase (3CT)	Red & Green color LED flicker alternately		GMP 80-3S/3SR model, Red/Green LED will flicker.	

Note) There are two red color LEDs for O.L (Overload) & Fault in the model of GMP80-3S/SR



# Setting method

## GMP Series Definite time

### Tunnel type mounting

#### 1. Check the Test/Reset button operation

- 1) Check if the wiring is correct (Refer to the wiring diagram)
- 2) Set the 'D-Time' and 'O-Time' knob to the min. ratings
- 3) When the 'Test' button is pressed under tripped condition, the 'O.L' LED is turned off

Note) In operation, even though you press the 'Test/Reset' button, the EMPR do not trip

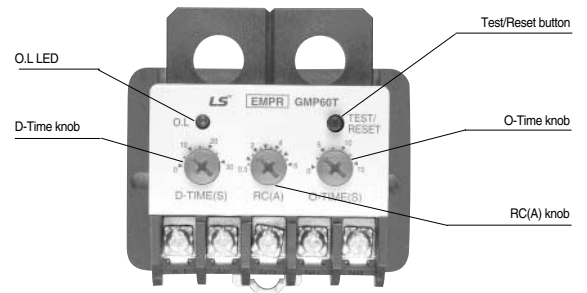

#### 2. Set the operating time

##### ● D-time (Delay time): 0.2~30 sec

The motor starting current, which flows when the motor is starting, is generally 600% of the rated current. It is the time during which the EMPR do not operated by over-current during the starting time

- 1) Set the delay time by use of the 'D-time' knob
- 2) In case you do not know the delay time, start the motor by setting the 'D-time' knob to the max. position and after checking the time during which the stiring current become stable, set the D-time (In general , the setting time is 3~5 seconds)

##### ● The operating time is the time during which the EMPR tripped by the over-current. The EMPR is tripped after the selected operation time

- 1) Set the operation time by the 'O-time' knob
- 2) If you set the 'O-time' to the min value, the EMPR is tripped at once

Note) Generally set it to 4~6 seconds

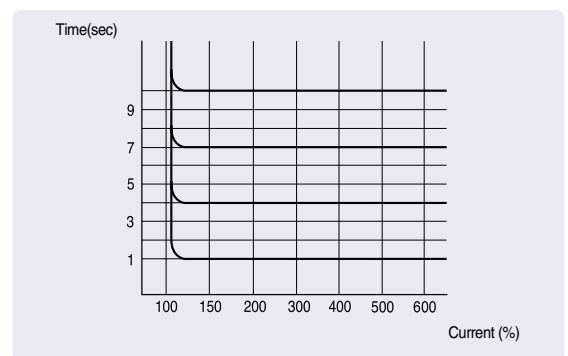

Definite time characteristics curve

#### 3. Set the operating current

- 1) Start the motor by setting the 'RC' knob to the maximum position
- 2) Under operating condition, rotate the 'RC' knob to the counterclockwise until the 'O.L' LED turned on & off. The current at this point is the value (100%) under real load condition
- 3) Rotate the 'RC' knob to the clock-wise until the 'O.L' LED turned off.  
Ex) When the 'O.L' LED flickering at 20A, the setting current will be 22A(=20x1.1)

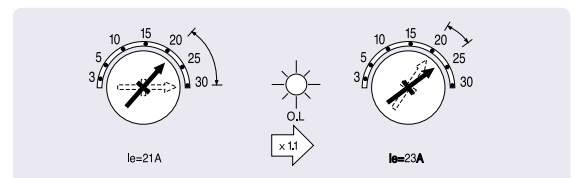

(ex: When the 'O.L' LED settings at 21A, the setting current will be 23A (=21\*1.1))

#### 4. Check the LED condition when operation

- 1) Over-current
  - The EMPR is not tripped during the D-time under over-current but the O.L LED turned on and off to indicate that the over-current flows
  - If the EMPR is tripped after D-time the O.L LED turned on

Condition	Red O.L LED	Note
Operation normal	Off	
Overcurrent	Flicker	
Trip over-current	On	The EMPR is tripped

# Electronic motor protection relays

## Setting method

### GMP60-TD(a) Type



#### ● Function & Setting menu

- 1) Automatic reset setting will work in the event of overcurrent trip
- 2) Func. A and b are to check the elapse time, not for setting
- 3) Undercurrent protection function will work at the current flow more than 0.4A
- 4) In case of changing the rating DIP S/W FUNC #1 should be changed accordingly
- 5) Function setting is allowable at TEST mode

- Turn off the power before changing a current type switch,  
and then be sure to adjust the current in the menu

#### ● Setting Menu

FUNC	SEL	Description	Remarks
1. C t 4	6R/60R	Current type selection	Set the same with rated current S/W
2. 0 - t	0.5/1~30 (SEC)	Trip time setting	-
3. d - t	1~60/1 (SEC)	Time delay setting	-
4. r - 0	0.5~6.0/5~60	Rated current setting	-
5. C t r	0.25/0.5/1~120	Current ratio setting	-
6. P - F	oFF/oN	Phase loss enable	-
7. U - 0	oFF/30~70 (%)	Undercurrent setting	For TDa model only
8. R - r	oFF/1~20 (MIN)	Automatic reset setting	For TDa model only
9. S - t	oFF/10~8160	Operation hour setting	For TDa model only
A t r t	-	Total running hour check	For TDa model only
b r - t	-	Running hour check	For TDa model only
S t o	-	Store	-

Note) 1. If operation hour set at 9.5-r is elapsed 0.0-H is displayed and the relay operates normally. (There is no additional relay output)

2. How to check 0.0-H and 0.0-B

Display	How to check			
0.0-B	Press SEL	Day displayed	Press SEL	Hour, Min displayed
	Press SEL	Operation hour displayed	Press SEL	Day displayed
0.0-H	Press SEL	Min displayed		

3. When power is OFF the data in unit of minute is deleted at 0.0-B

4. Operation hour at 0.0-B is the total running hour before the motor is oFF and displayed in Day, Hour and Min.  
When motor is OFF the data is deleted.

#### ● Fault status configuration

Protection	FND	Description	Remarks
Over current	O - L	More than set current : Within the set time	
Undercurrent	U - C	Lower than the undercurrent set ratio : Within 3S	GMP60TDa
Phase Loss	PF - r	Over 70% of the rate of unbalance : Within 3S	R Phase Loss
	PF - t	Over 70% of the rate of unbalance : Within 3S	T Phase Loss
LOCK	Loc	More than lock set current ratio : Within 1S	
Approaching Running Time	OrH	When Running time approaches at setting time	GMP60TDa

Note) When the 'FUNC' Key and 'SEL' Key are pushed simultaneously, a last trip cause appears on the display window.

# Setting method

## GMP60-3TZ(R) / 3TN(R) Type



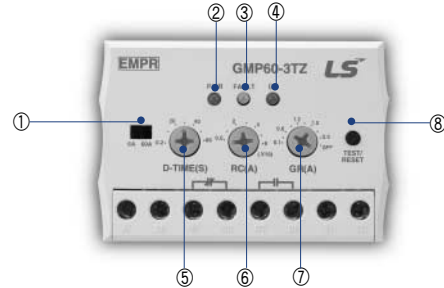



- **Trip curve: definite time characteristics**
- **Protective function: overcurrent, locked rotor, phase loss, phase unbalance, ground fault (and phase reverse)**
  - 1) Overcurrent: trip within 3 sec. after D-time at 105% or more
  - 2) Locked rotor: trip within 1 sec. after D-time at 300% or more
  - 3) Phase loss: trip within 3 sec. (phases unbalance rate over 70%)
  - 4) Phase unbalance: trip within 5 sec. (phases unbalance rate over 50%)
  - 5) Ground fault: trip within 0.5 sec. after D-time at over 110% or under 90% of set value
  - 6) phase reverse: trip within 1 sec. when any two phases out of three
- **Overcurrent trip time**
  - 1) Time delay(D-time) setting: between 0.2-60 sec.
  - 2) Trip time(O-time) setting: fixed at 3 sec.
- **Last fault cause data stored**
  - to display it press TEST/RESET button 2 times within 0.5 sec.
  - PWR LED flicking in case of no fault



Note) 1. Make power off before changing the rated current with S/W ①  
 2. The setting range of RC (A) KNOB ⑥ is recognized as 0.5 - 6A or 5 - 60A according to the setting value of S/W ①. The value of the scale for RC (A) KNOB ⑥ is 0.5, 1, 2, 3, 4, 5, 6 or 5, 10, 20, 30, 40, 50, 60(A) from the left.  
 3. Last fault cause function indicates the LED status for the last TRIP.

Note) In case of load less than minimum rating of EMPR make the number of penetrating through CT more than 2 times. If not, error may happen to phase loss.

### ● Status of LED configuration

NO	Function	Setting	Description	Remark
①	6A/60A	Slide switch	Maximum rated current (6A/60A) setting	-
②	PWR.	Red LED	Lights up when power is ON	Blinking in the failure mode
③	FAULT	Red / Green LED	Overcurrent / unbalance in progress:  Overcurrent TRIP:  Phase loss (unbalance) TRIP · R-phase:  · S-phase:  · T-phase:  Reverse phase: 	■ Red LED ■ Green LED
④	GF	Red LED	Lights up after blinking in the event of ground fault	-
⑤	D-TIME (S)	KNOB	Delay time (0.2 to 60 sec.)	-
⑥	RC (A)	KNOB	Rated current setting: 0.5~6A/5~60A	-
⑦	GR (A)	KNOB	Sensitivity current setting (0.1~2.5A)	Zero phase current detection type
			Sensitivity current setting (0.5~6A)	Residual current detection type
⑧	TEST/RESET	BUTTON	TRIP / RESET alternately perform 1. Check relay contacts - displays fault cause 2. RESET	Pressing 2 times within 0.5 sec. the final failure cause is displayed

# Electronic motor protection relays

## Setting method DMP Series

### 1. Check the operation of the Test/Reset button

- 1) Check the wiring method
- 2) Press the Test/Reset button and then test is displayed on the LED and the DMPR is tripped
- 3) Press the Test/Reset button again and then it is reset

Note) The Test/Reset is not available when a motor is rotating.

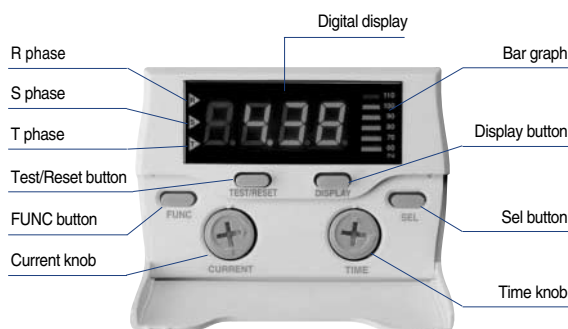

### 2. Shift the mode by pressing the FUNC key and then select the values by the Sel key

- 1) First shift to the test mode by press the "Test/Reset" button and then set the functions by press the "FUNC" button
- 2) Each time you press the "FUNC" button, the function mode switches from 1.CHA mode to Sto mode.  
When the mode that you want to change is displayed, push the "Sel" button to select the value you want.  
After you select the value, press the "FUNC" button to finish the settings and it displays the next mode
- 3) If no button is pressed in the selection mode, it remains in that mode
- 4) If you select the inverse time characteristics it skips the mode 2 (Definite O-time) and go to the mode 3 (Reverse phase)
- 5) Alt is the alert setting mode. It displays the load rate of the current setting value by the bar LED (60~110%)
  - If the current is higher than the setting value, the bar LED is switched on and off and the AL relay (07-08) make close and open in 1sec interval unit the EMPR is tripped (Pre-alarm function)
  - If the 5. Alt mode is set to off, the AL relay make close after the EMPR is tripped (Normal open contact)
- 6) To finish the settings you have to press the "Sel" button in the Sto mode

Alarm signal (Alert function)

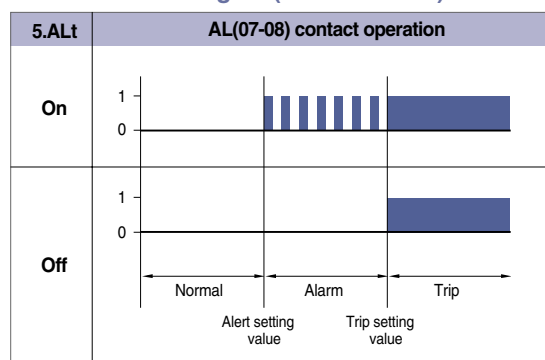

### Setting Menu

FUNC	Sel	Functions	Note
1.CHA	1nu/dEF	Inverse or definite time characteristics	Default is inverse time characteristics
2.dEF	0~30	Set the O-time (Definite time only)	For D-time setting, use the time knob
3.rP	oFF/oN	Reverse phases protection	Default is "Off"
4.Und	oFF/30~70 (%)	Under current protection	Default is "Off" <sup>Note1)</sup>
5.ALt	oFF/60~110 (%)	Alarm function (With pre-alarm function)	Default is "Off"
59-F	oFF/0.05~1(5EC)	Ground fault and Setting the operating time	Default is "Off" (Z type)
6.StL	oFF/oN	Stall function	Default is "Off"
7.Loc	oFF/200~900 (%)	Lock function	Default is "Off"
8.Ct	1~120	CT ratio	Default is 1:1 <sup>Note2)</sup> (DMP06 Modle)
9P-F	oN/oFF	Phase failure	Default is "On" to store
A9Fd	oFF/oN	Setting delay of Ground Fault	Available for SZa/TZa
B.StA	0~120	Operating time setting (Month)	DMP□-Sa/Ta/SZa/TZa model
C.StH	10~730	Operating time setting (Hour)	
d.tRH	R000,000.0	Displaying total operating time (Month, Hour)	
E.rRH	R000,000.0	Displaying operating time (Month, Hour)	
Sto	Sto	Store	Push the SEL button to store

Note) 1. Set the under current value from above 350mA  
2. Do not change the CT ratio in 36, 60 type

# Setting method

## DMP Series



### 3. Adjust the operating time by the time knob

#### ● Inverse time characteristics

- 1) Select the inverse time in the 1. CHA mode, the default operating time is 600% of the setting current
- 2) The setting range of the operating time is 0~60sec. Set the time by considering the motor start time
- 3) When it is over the setting time, the EMPR operate in accord with the hot characteristics curve

#### ● Definite time characteristics

- 1) Select the definite in the 1. CHA mode, it is operated by the definite time characteristics
- 2) D-time means the time that delays the operating time when the motor is starting
- 3) The setting range of the operating time is 0~60sec. Set the time by considering the motor start time
- 4) Set the O-time at the setting mode 2. dEF and the range is 0~30sec

### 4. Adjust the operating current by the current knob

- 1) Set the operating current based on the rated current that is described in the name plate. Generally set the 110~115% of the real load current in the normal load condition
- 2) There are 3 types according to the current range (6 / 36 / 60). When you use the external CT you can see the real current by setting the CT ratio
- 3) You can easily set the current value by refer to the load rate which is displayed on the bargraph (Approx. 90% load rate)

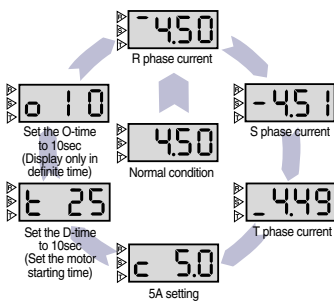

### 5. Check the setting state by the display key

- 1) In normal condition it display the maximum current among the three phase current
- 2) Each time you press the "Display" button you can see the current and values
- 3) If no button is pressed for 3~4 seconds. It returned to the normal condition

### 6. Check the causes of the fault by look at the display unit

The causes of the fault is switched on and off for 0.5sec interval. If you press the "Display" button at this time, you can see the values and the causes of the fault

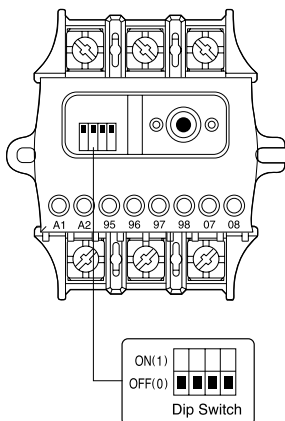
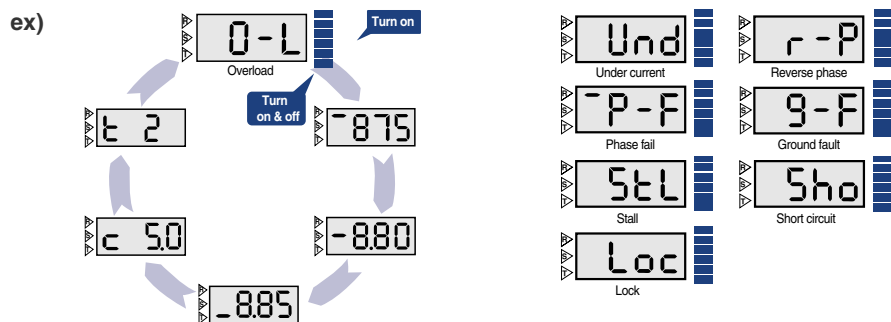

### Zero current sensitivity setting

Sensitivity (mA)	DIP S/W			
	1	2	3	4
100	○	○	○	○
200	1	○	○	○
500	○	1	○	○
1000	○	○	1	○
1500	○	○	○	1
2000	○	○	1	1
2500	1	1	1	1

Note) 1. Please use ZCT for LS EMPR.

# Electronic motor protection relays

## Operation and Setting

### IMP Series



#### 1. Test/Reset

- 1) Check wires.
- 2) Press the Test/Reset key once. Then “TEST” is displayed and the EMPR is tripped.
- 3) Press again the Test/Reset key to reset the EMPR.

*Note) While the motor is running, the Test/Reset key does not work.*

#### 2. Setting

- 1) Press the Test/Reset key once. Then “TEST” is displayed and the EMPR is tripped.
- 2) Press the Enter key. Then “P-99” is displayed. Use the Up/Down keys to change the password.
- 3) Press the Enter key to enter A-gr setup mode.  
Use the Up/Down keys to select a group and Press the Enter key to enter the selected group.  
Press the Test/Reset key to move back to the previous mode.
- 4) In the A-Grp mode, Press the Enter key. Then “1.CHA” is displayed.  
Use the Up/Down keys to select an item and Press the Enter key to enter the selected item.  
Press the Test/Reset key to move back to the previous mode.
- 5) Use the Up/Down keys to set up the value and Press the Enter key to save it.

*Note) When the power is supplied first or is resupplied after a power failure, must set up the date in b-gr, 5.S-d.  
Set up the rated current S/W while the power is off.*

#### 3. Quick Setup

- 1) Press the “Up and Enter” keys at the same time. “UPLD” is displayed and settings are uploaded to the display.
- 2) Insert the display to the body without settings, and then press the Test key to enter the test mode.
- 3) Press the “Down and Enter” keys at the same time. “TEST” is displayed and downloading is completed.
- 4) Press the Test key to return to the normal mode.

*Note) Communication settings cannot be uploaded or downloaded.*

#### 4. Setting Checkup

- 1) Press the Enter key.
- 2) Use the Up/Down keys to select a group and Press the Enter key to enter the selected group.  
Press the Test/Reset key to move back to the previous mode.
- 3) Use the Up/Down keys to select an item and Press the Enter key to enter the selected item.
- 4) Press the Enter key again to check settings.

#### 5. Failure Event Checkup

- 1) Press the Up and Down keys at the same time to display “1.O-C” (recent failure events).  
*Note) When no failure events are stored, “1.non3” is displayed.*
- 2) Use the Up/Down keys to select an event and press the Enter key to go to the selected event.
- 3) The R-phased failure current is displayed. Every time the Down key is pressed, S-phased failure current, T-phased failure current, overload rate and date are displayed one after the other.
- 4) Press the Test/Reset key to move back to the previous mode.
- 5) Press the Up and Down keys at the same time to get out of the failure event checkup mode.

#### 6. Forced Thermal Reset

When the system is tripped while it is in the thermal inverse time mode, if you want to turn the EMPR into the cold mode by resetting the motor’s heat amount, Press the Enter and Test/Rest keys at the same time.

*\* When a trip occurs due to the thermal excess current, if the motor is started right after it is reset, as the motor is hot, it is highly likely that the motor is tripped again.*

# Operation and Setting

## IMP Series



### Setting Menu (A Group)

Group	Menu	Setting Value	Description	Default Value
A	1CHA	dEF/th/n-th	Operation Characteristics (Definite/Thermal Inverse/Inverse)	n-th (Inverse)
	20-t	1~60s	Operation Time (sec)	60
	3d-t	1~200s	Delay Time (sec)	200
	4r-C	0.5~10A/5~100A	Rated Current (10/100A)	10/100A
	5Ct-r	0.25, 0.5, 1~200	CT Ratio (4 times, twice, once)	1 <sup>Note</sup>
	6Loc	OFF, 200~800%	Lock Protection (sec)	OFF
	7StL	OFF, 150~500%	Stall Protection (sec)	OFF
	8P-F	OFF/On	Open Phase	OFF
	9P-U	OFF, 10~70%	Unbalance Protection (%)	OFF
	10rP	OFF/On	Reverse Phase	OFF
	11UC	OFF, 30~90%	Under Current Protection (%)	OFF
	12gF	OFF, 0.03, 0.05/0.1~3A	Ground Fault Operation Current (Zero sequence CT)	OFF
	13gn	OFF, 20~500% (FLCmin)	Ground Fault Operation Current (Residual circuit)	OFF
	14gt	0.05, 0.1~1.0s	Ground Fault Operation Time	-
	15gd	On/OFF	Ground Fault Delay During Start	ON
	16IC	OFF, 500~1000%	Instantaneous Protection (%)	OFF
	17Io	ALt/TriP	Instantaneous Warning/Operation	TriP

Note) 1. When the rated current S/W is 100A, the CT ratio is not displayed.  
2. Some menus are not displayed if relevant functions are not available.

### Setting Menu (B Group)

Group	Menu	Setting Value	Description	Default Value
B	1E-r	On/OFF	Electric Reset	On
	2A-r	OFF, 1~20 min	Automatic Reset	OFF
	3r-t	Hour/Minute	Run Time	Time Check
	4Srt	OFF, 1~8760Hour	Run Time Setup (Hour)	-
	5S-d	2009/01.01/00:00	YY/MM/DD/ HH:MM (View/Setup)	-
	6trt	Day/hour:minute	Total Run Time	Time Check
	AR-d	0.5~10/5~100A	Analog output	A420 Model
	ARdr	1~247	Communication Address	M485 Model
	bbPS	96/192/384	Communication Speed	
	cS-P	On/OFF	SWAP	

Note) 1. When the power is supplied first or is resupplied after a power failure, must set up the date (5.S-d).  
2. Automatic reset is only possible in case of an excess current trip.

# Electronic motor protection relays

## Operation and Setting IMP Series

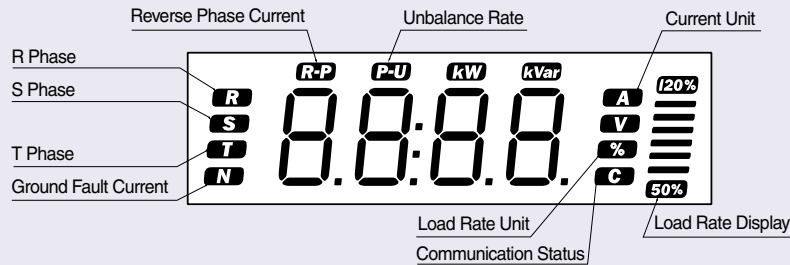

Note) kW, kVar, and V indicate the specification of the voltage models (under development).

### Operation Display

Display	Description	Remark
$\overline{O-C}$	Over Current Trip	Operate within predefined time.
$\overline{U-C}$	Under Current Trip	Operate within 3 seconds.
$\overline{P-F}$	Open Phase Trip	Operate within 1.5 seconds when the unbalance rate is over 70%.
$\overline{P-U}$	Unbalance Trip	Operate within 3 seconds.
$\overline{Loc}$	Lock Trip	Operate within 0.5 seconds.
$\overline{StL}$	Stall Trip	Operate within 3 seconds.
$\overline{r-P}$	Reverse Phase Trip	Operate within 0.1 second.
$\overline{g-F}$	Ground Fault Trip	Operate within predefined time.
$\overline{Sho}$	Instantaneous Trip	Operate within 0.05 seconds.
$\overline{O-H}$	Elapsed Time (No Trip)	The operation time is reset when the Reset key is pressed.
$\overline{CErr}$	Communication Fault between Body and Display (Press the ENTER/RESET key to return to the normal mode)	

### IMP Specifications for Low Voltage 3-Phase Induction Motors (Reference)

Full Load Current for the Motor	IMP Settings			External CT	Motor Output (Less than kW)		
	Current Selection S/W	Wire Tunnel	CT ratio		220V	380V	440V
0.7A or less	0.5~10A	4 times	0.25	-	0.1	0.18	0.2
0.7~1.6A		Twice	0.5	-	0.25	0.55	0.6
1.6~8A		Once	1	-	1.5	3	3.7
7~100A	5~100A	Once	1	-	25	45	55
90~120A	0.5~10A	Once	30	SCT-150	30	55	55
120A~160A		Once	40	SCT-200	45	75	90
160~240A		Once	60	SCT-300	55	110	132
240~320A		Once	80	SCT-400	90	160	160
320~400A		Once	100	500 : 5	110	200	200
400~480A		Once	120	600 : 5	132	250	250
480~640A		Once	160	800 : 5	160	320	320

Note) 1. This table is written based on the full load current.  
2. The CT is selected as a reference for the EMPR's current setting range.

### Analog (DC 4~20mA) Output / Communication

- The biggest current out of measured 3-phase currents is converted into DC 4mA~20mA and the current measured remotely by digital meter can be displayed.
- When there is no current, 4mA is sent. If the current goes beyond the predefined value, 20mA is sent.
  - Output Current =  $\frac{16mA}{Setting} \times Load\ Current + 4mA$  (Settings are changed in A.t-d of b-gr)
- When the system is the 0.5A~10A setting mode, measurement starts from 0.3A. When the system is the 5A~100A setting mode, measurement starts from 3A. Thus, when the current is under 0.3A (3A), 0A is measured and output is 4mA. (To measure the load current correctly, an appropriate CT should be used).

Note) The allowable burden is less than 500Ω .

Considering the receiver resistance (usually 250Ω ) and track resistance), the shielding cable should be used.

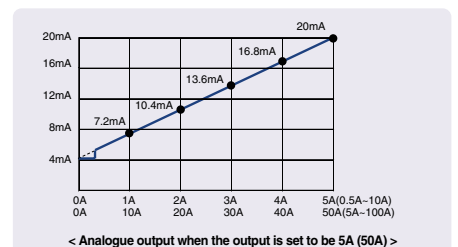
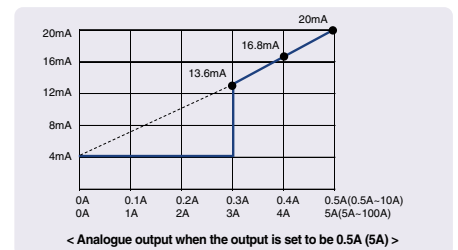

### Communication Spec. :

Refer to G-41 page and LSIS Homepage ([www.lsis.biz](http://www.lsis.biz))



# Dimensions

## GMP Series

GMP22-2P (1c) Sol

GMP22-2PD (1c) Sol

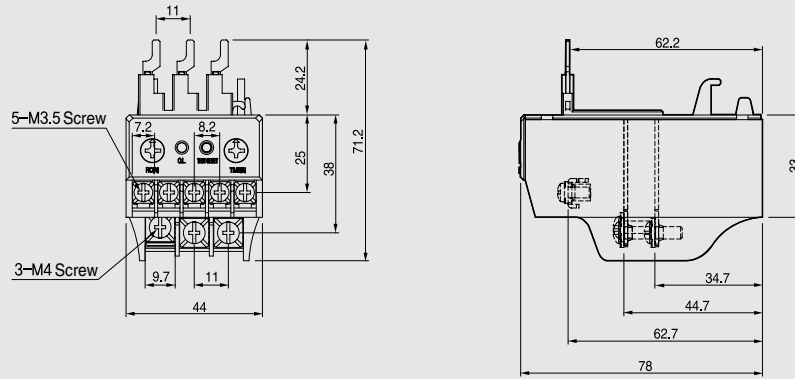

0.15kg

GMP22-2P (1a1b) Sol

GMP22-3P Sol

GMP22-2PA (1a1b) Sol

GMP22-3PR Sol

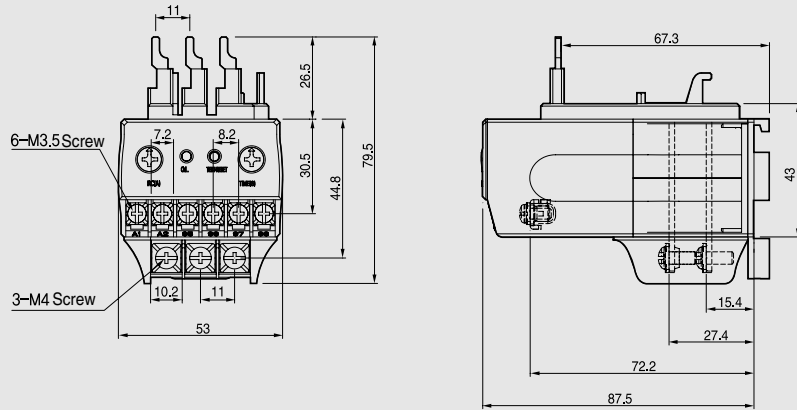

0.18kg

GMP40-2P Sol

GMP40-2PD Sol

GMP40-2PA Sol

GMP40-3P Sol

GMP40-3PR Sol

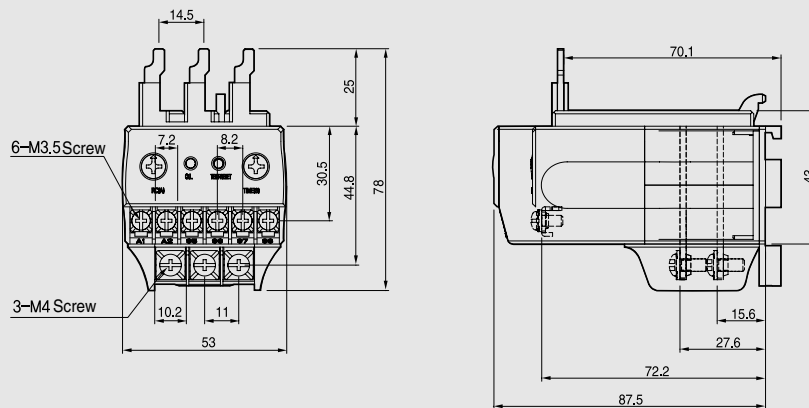

0.20kg/0.22kg

GMP80-2S

GMP80-3S

GMP80-3SR

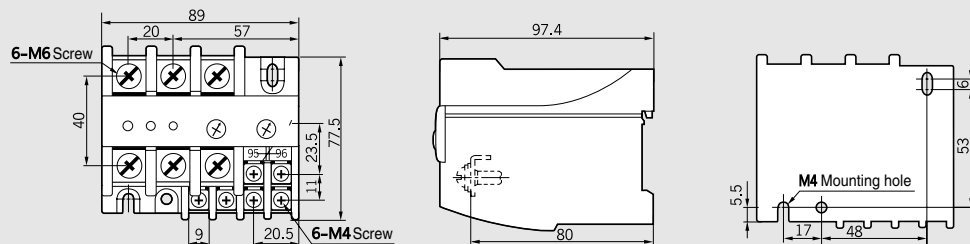

0.42kg/0.46kg

# Electronic motor protection relays

## Dimensions GMP Series

GMP22-2S

GMP22-3S

GMP22-3SR

GMP40-2S

GMP40-3S

GMP40-3SR

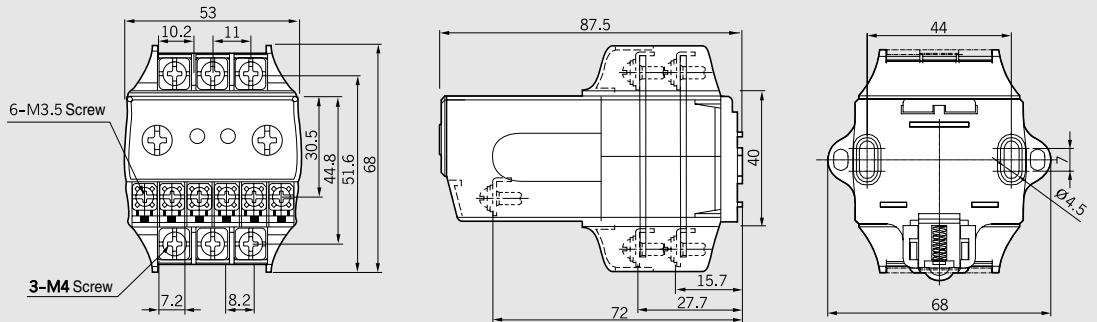

0.19kg/0.21kg

GMP22-2T

GMP22-3T

GMP22-3TR

GMP40-2T

GMP40-3T

GMP40-3TR

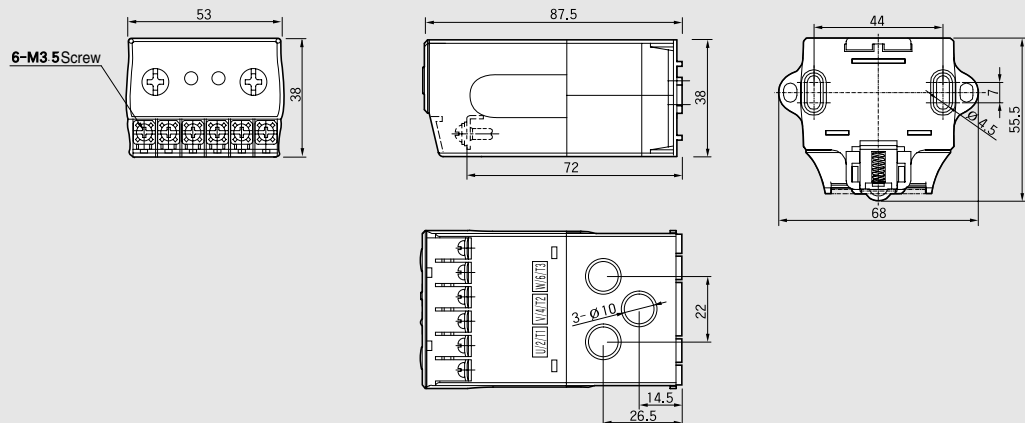

0.14kg/0.16kg

GMP60T

GMP60TE

GMP60TA

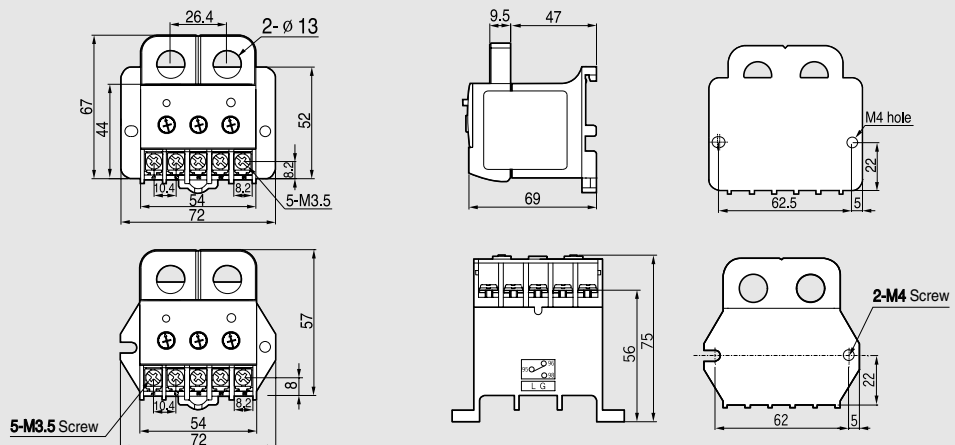

0.14kg

# Dimensions

## DMP Series

GMP60-TD

GMP60-TDa

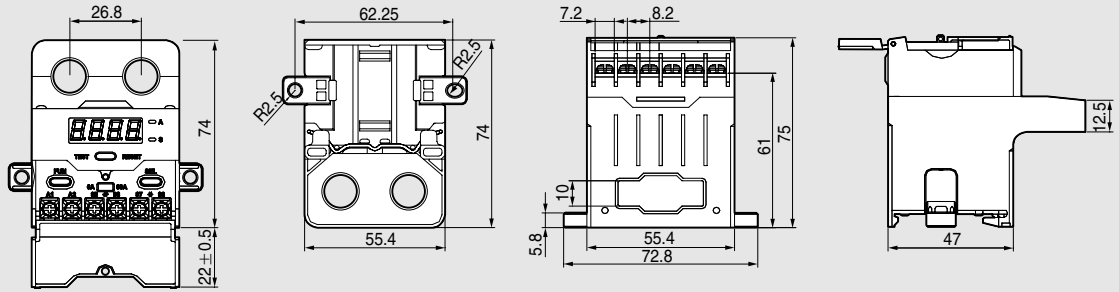

0.25kg

GMP60-3TZ, TZR

GMP60-3TN, TNR

GMP60-3T, TR

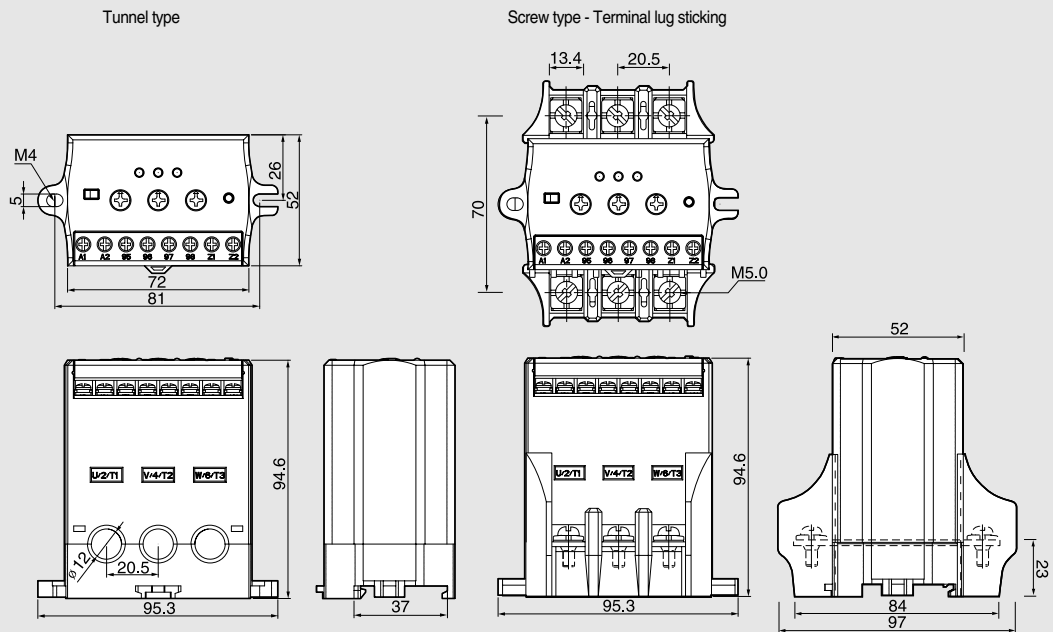

## Terminal arrangement

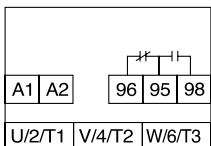

GMP22-2P (1c)  
GMP22-2PD (1c)  
GMP22-2PA (1c)

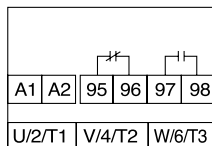

GMP22-2P (1a1b)  
GMP22-3P  
GMP40-2P/3P

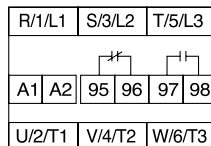

GMP22-2/3S  
GMP40-3/3S  
GMP80-2/3S

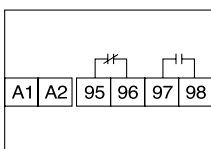

GMP22-2/3T  
GMP40-2/3T

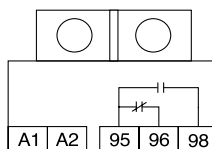

GMP60-T/TE/TA

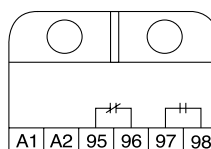

GMP60-TD  
GMP60-TDa

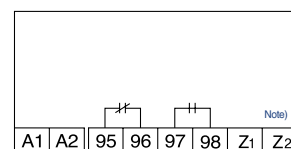

GMP60-3TZ, TZR  
GMP60-3TN, TNR  
GMP60-3T/3TR

Note) 1. Only for the GMP60-TZR module.

2. Aux. Contacts are operate when power applied.



EMPR/DMPR

# Electronic motor protection relays

## Dimensions DMP Series

- DMP□-S
- DMP□-SZ
- DMP□-Sa
- DMP□-SZa

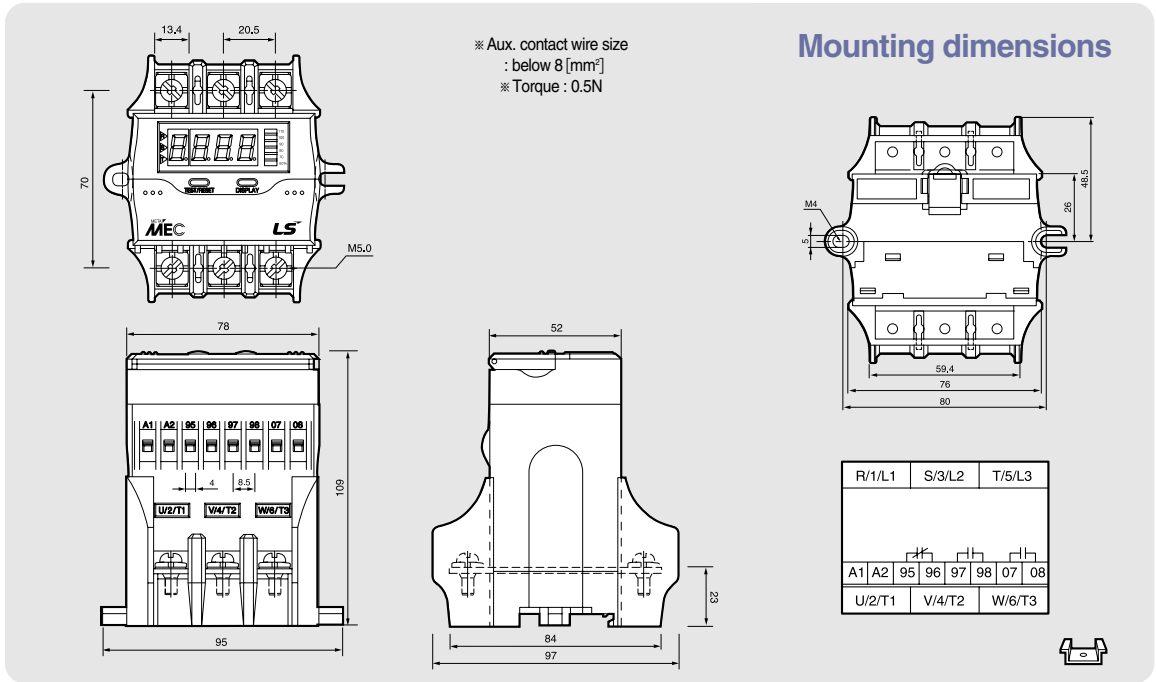

0.7kg

- DMP□-S
- DMP□-SZ
- DMP□-Sa
- DMP□-SZa

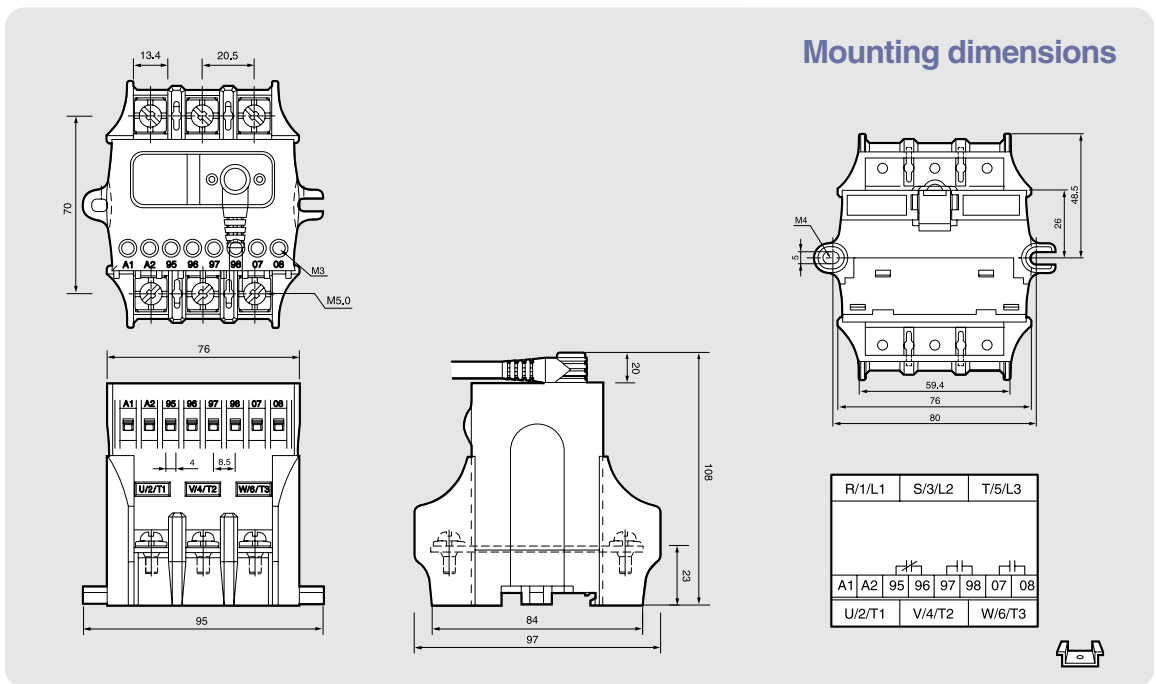

0.64kg

### Panel mounting

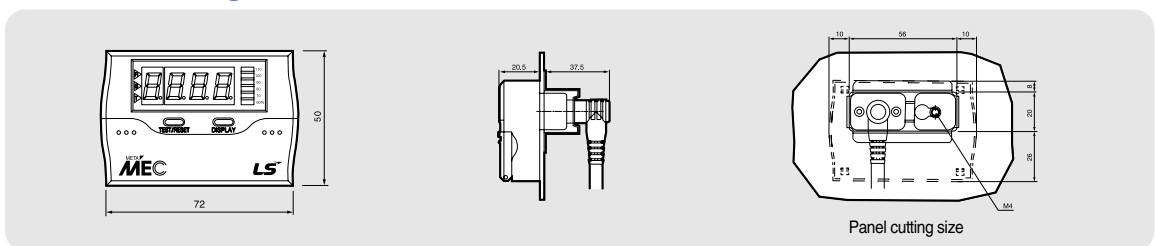

- Note) 1. In extension type, the digital EMPR is calibrated with combining the display unit and mainbody so, please cautious not to combine the display unit and mainbody with different part No.  
 2. The 07-08 contacts are the ZCT input terminal (Digital EMPR with ground fault function)

# Dimensions

## DMP Series

- DMP□-T
- DMP□-TZ
- DMP□-Ta
- DMP□-TZa

※ Wire size to penetrate a CT :below 22 [mm<sup>2</sup>]

### Mounting dimensions

R/1/L1	S/3/L2	T/5/L3
A1	A2	95
96	97	98
07	08	
U/2/T1	V/4/T2	W/6/T3

0.56kg

- DMP□-T
- DMP□-TZ
- DMP□-Ta
- DMP□-TZa

### Mounting dimensions

R/1/L1	S/3/L2	T/5/L3
A1	A2	95
96	97	98
07	08	
U/2/T1	V/4/T2	W/6/T3

0.5kg

### Panel mounting

Panel cutting size

Note) 1. In extension type, the digital EMPR is calibrated with combining the display unit and mainbody so, please cautious not to combine the display unit and mainbody with different part No.  
 2. The 07-08 contacts are the ZCT input terminal (Digital EMPR with ground fault function)

# Electronic motor protection relays

## Dimensions IMP Series

### One-Body Type

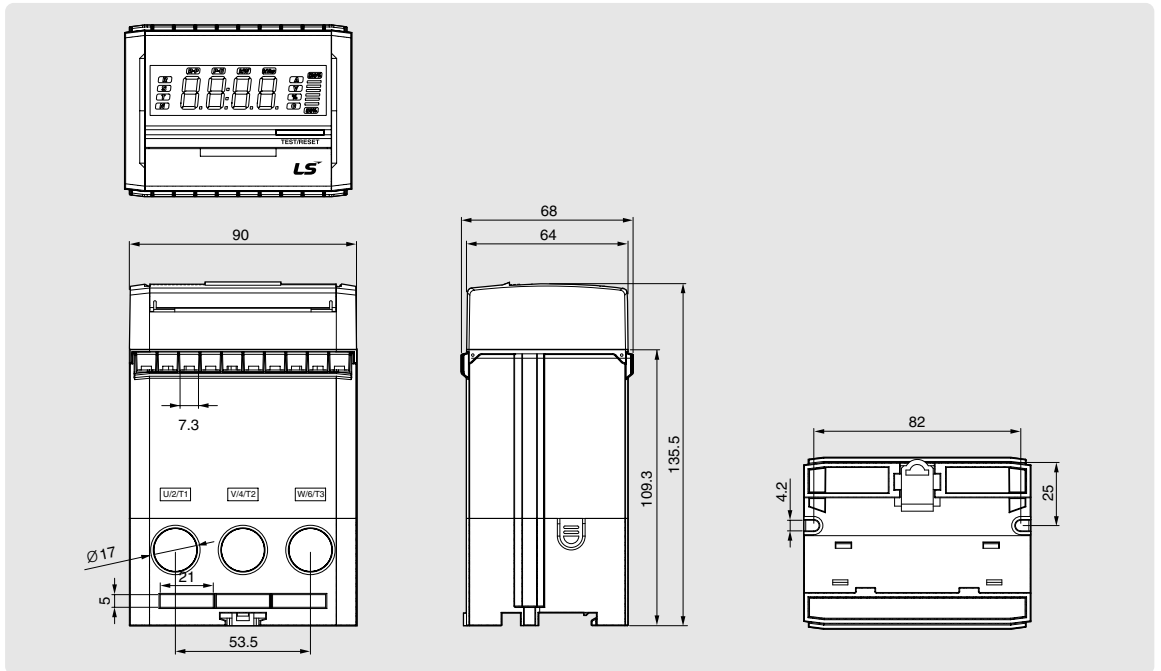

### Separate Body Type

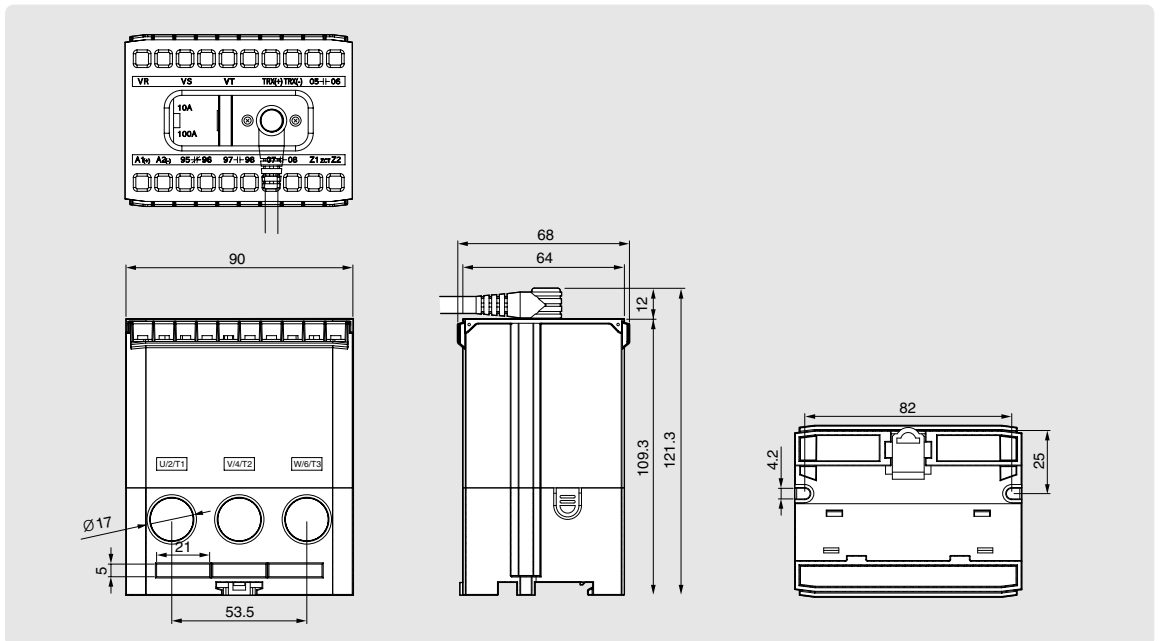

## Panel mounting

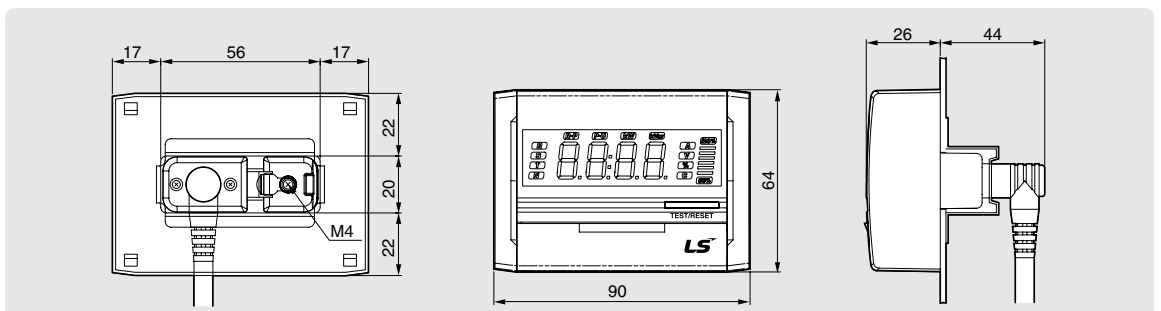

Note) The cable should be purchased separately (1m/1.5m/2m/3m).

# Wiring method

## GMP Series

GMP22-2P (1c)

GMP60T (1c)

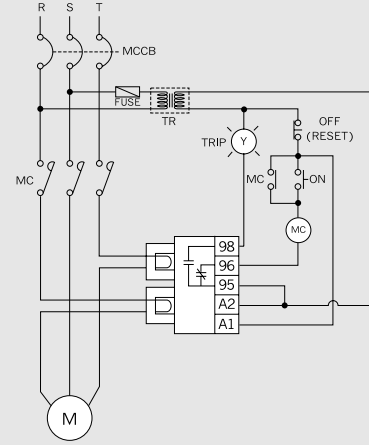
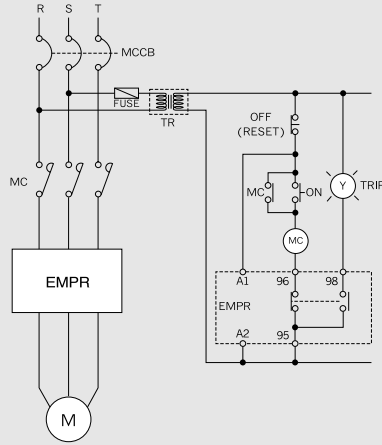

GMP□-□ (1a1b)

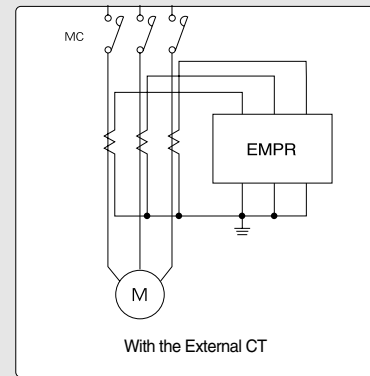
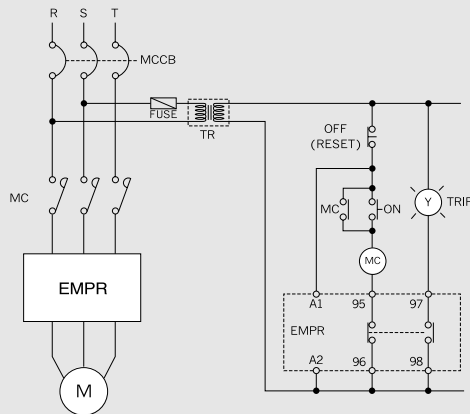

GMP60-3TZ, TZR

GMP60-3TN, TNR

GMP60-3T, 3TR

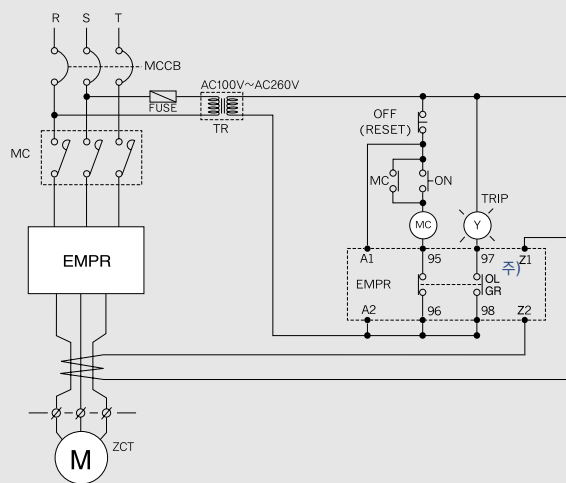

Note) 1. The Z1, Z2 are the ZCT input terminal (GPM60-3TZ/TZ type)  
2. Aux. contacts are operate when power applied.

G

EMPR/DMPR

# Electronic motor protection relays

## Wiring method

### DMP Series

DMP-S/Sa

DMP-T/Ta

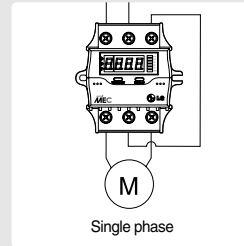
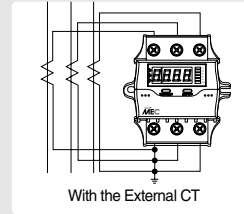
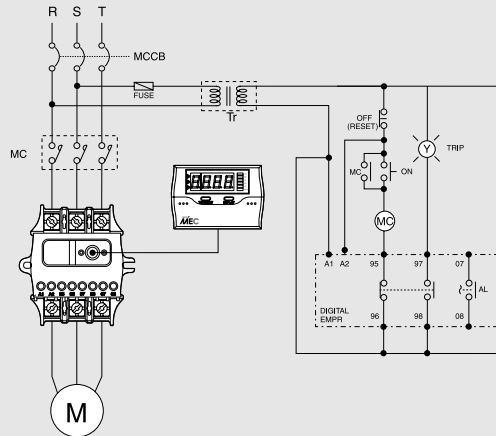

Note) When the single-phase motor is used, reverse phases protection should be set off.

DMP-SZ/SZa

DMP-TZ/TZa

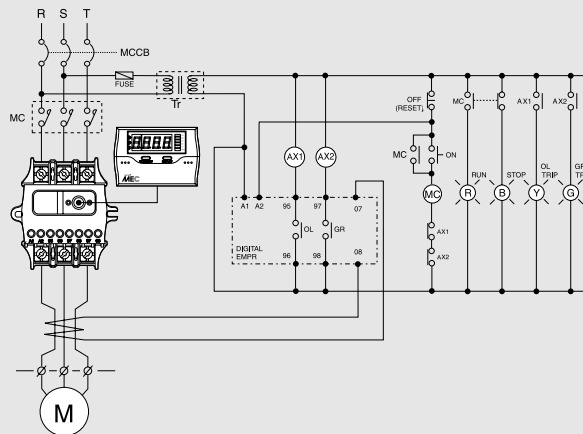

DMP-SZ/SZa

DMP-TZ/TZa

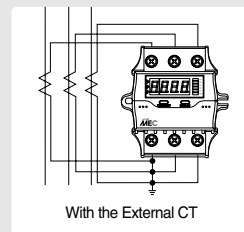
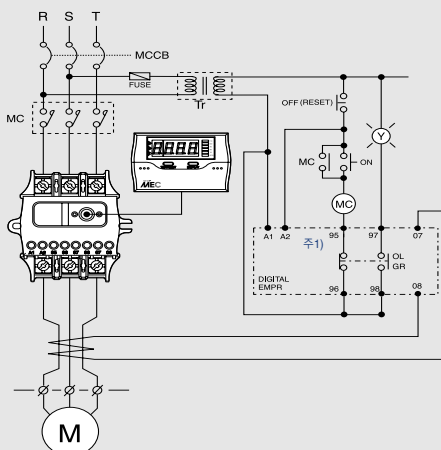



# Wiring method

## IMP Series

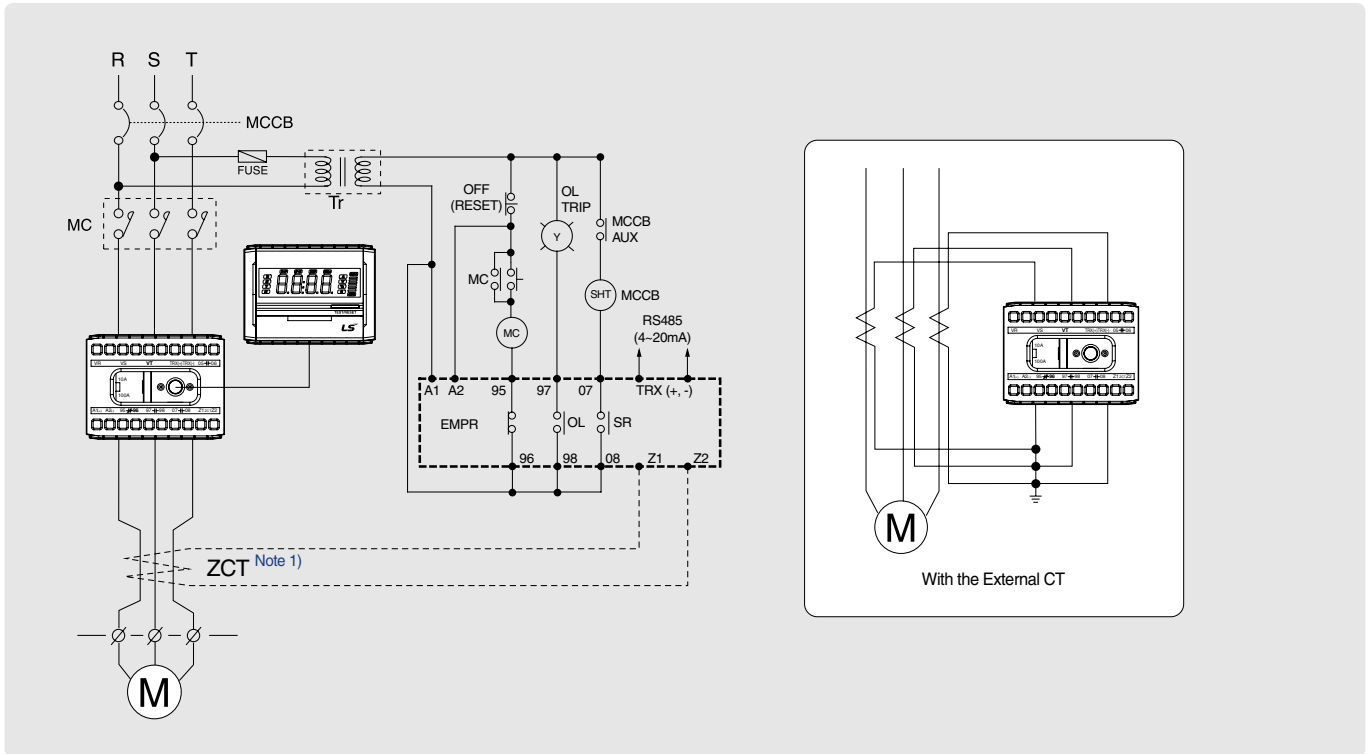

Note) 1. When the zero-phase-sequence current transformer is used to detect ground faults, connect the ZCT.  
 2. When the single-phase motor is used, all phases are connected except the S phase, and open-phase, unbalance and ground fault should be set OFF.

### Terminal layout

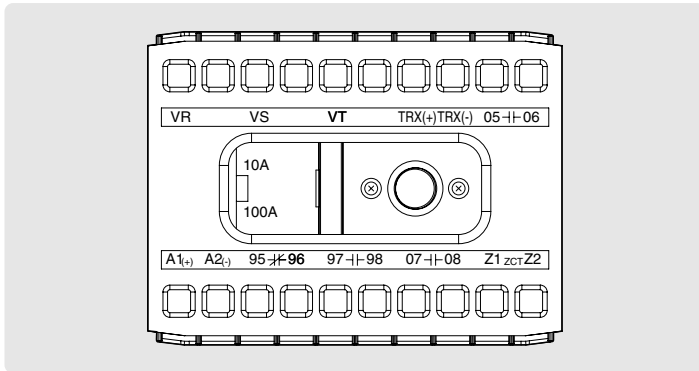

### Communication specification

- Operation mode: Differential
- Distance: Max. 1.2km
- General RS-485 shielded twist 2-pair cable
- Baud rate: 9600/19200/38400bps
- Transmission method: half-Duplex
- Max. In/Output voltage: -7V~+12V

### Terminal Configuration

Engrave	Description	Remark
A1(+), A2(-)	Input terminal for operation power	AC/DC85~245V
95-96	When the power is ON (NC contact output)	In case of an instantaneous trip, if 17.lo is ALT, it is NC, and if 17.lo is Trip, it is NO.
97-98	When the power is ON (NC contact output)	In case of an instantaneous trip, regardless of 17 .lo setup, it is NC.
07-08	Converted to the NC mode only when an instantaneous trip occurs.	
Z1, Z2	Output terminal for the zero-phase sequence current transformer	Specific ZCT (for the EMPR)
TRX(+)	RS485 terminal (TRX+) Or 4~20mA (+) output	M485, A420 Type
TRX(-)	RS485 terminal (TRX-) Or 4~20mA (-) output	
10A/100A	Max. rated current change S/W	10A : 0.5~10A, 100A : 5~100A
VR/VS/VT	3-phase voltage input terminal	N/A
05-06	Output terminal for voltage protection	

Note) 1. The 3-phase voltage input terminal and 05-06 output terminal should be connected only for voltage protection models, which will be released in the future.  
 2. For RS485 connection, the terminal resistance should be 120Ω .  
 3. For 4~20mA current, the maximum burden should be less than 500Ω .

# Electronic motor protection relays

## Accessories

### CT, ZCT, Cable and Terminal

#### ● CT (Current Transformer)

##### DCT (Current Transformer)

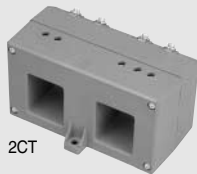

##### Dimension

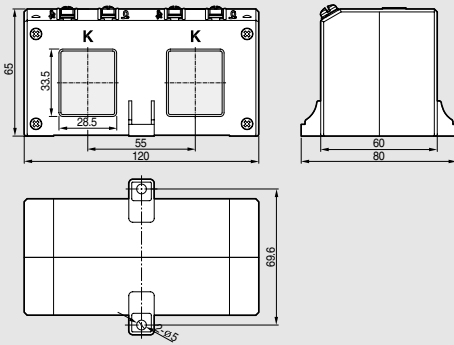

##### Ratings

Type		2CT
CT ratio	DCT-100	100 : 5A
	DCT-150	150 : 5A
	DCT-200	200 : 5A
	DCT-300	300 : 5A
	DCT-400	400 : 5A
Class		1.0
Burden		5VA
Insulation voltage		600VAC
Insulated impulse voltage		2kV
Insulation resistance		10MΩ (DC 500V Megger)
Mounting		Panel

Note) Please use DCT for LS Electronic Motor Protection Relay only.

##### With GMP60T

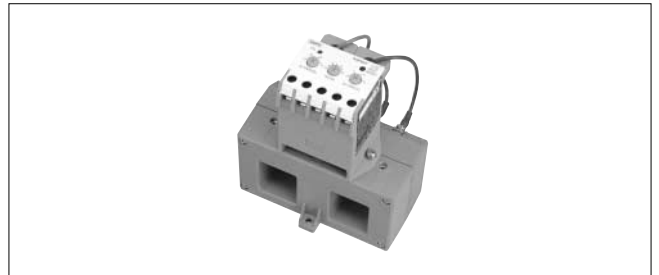

##### SCT (Current Transformer)



##### Dimension

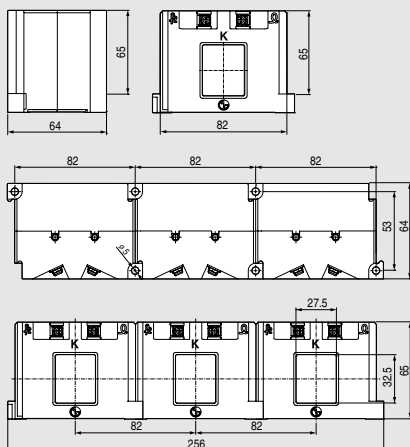

##### Ratings

Type		3CT
CT ratio	SCT-100	100 : 5A
	SCT-150	150 : 5A
	SCT-200	200 : 5A
	SCT-300	300 : 5A
	SCT-400	400 : 5A
Class		1.0
Burden		5VA
Insulation voltage		600VAC
Insulated impulse voltage		2kV
Insulation resistance		10MΩ (DC 500V Megger)
Mounting		Panel

Note) Please use SCT for LS Electronic Motor Protection Relay only.

##### With GMP60-3T/DMP/IMP

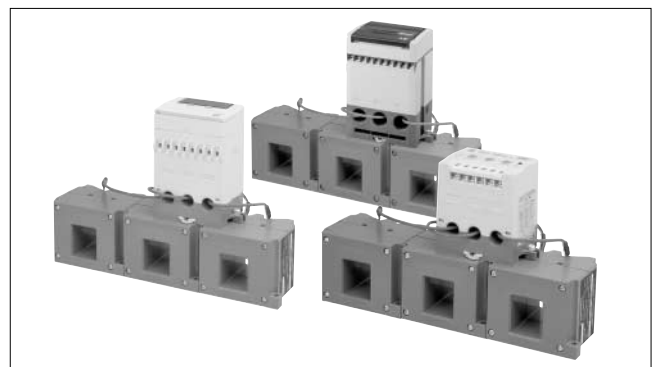

# Accessories

## CT, ZCT, Cable and Terminal

### ● ZCT (Zero Sequence CT)

#### Ratings

Type	Diameter (A)	Ratio	Weight (kg)	Model
ZCT, D30	30	100mA/40~55mV	0.5	LZT-030
ZCT, D50	50		0.7	LZT-050
ZCT, D65	65	200mA/100mV	0.9	LZT-065
ZCT, D80	80		1.5	LZT-080

#### Dimension

ZCT 30

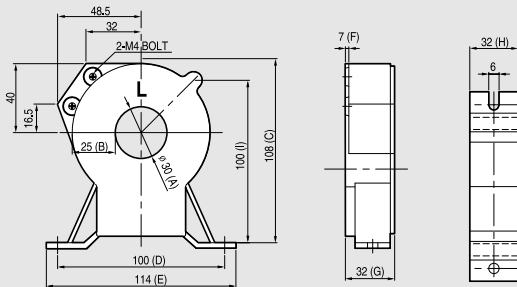

Unit (mm)

Model	A	B	C	D	E	F	G	H	I	∅
LZT-030	30	25	108	100	114	7	32	32	110	6

ZCT 50, 65, 80

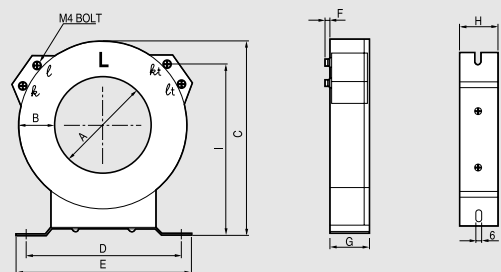

Unit (mm)

Model	A	B	C	D	E	F	G	H	I	∅
LZT-050	50	25	131	100	122	7	32	36	114	6
LZT-065	65	26	143	114	133	7	39	37	126	6
LZT-080	80	34	174	160	180	7	40	40	151	6

### ● Other Options

#### Cable

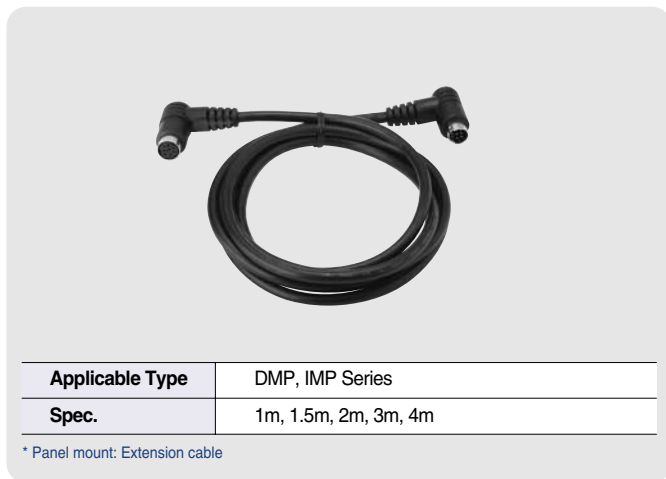

Applicable Type	DMP, IMP Series
Spec.	1m, 1.5m, 2m, 3m, 4m

\* Panel mount: Extension cable

#### Terminal Block

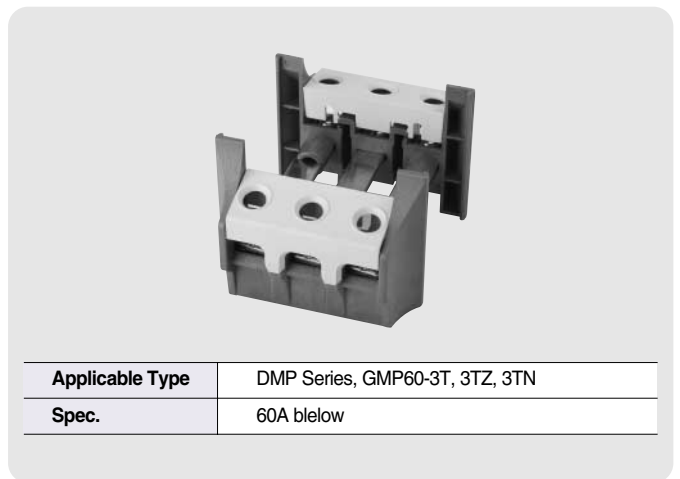

Applicable Type	DMP Series, GMP60-3T, 3TZ, 3TN
Spec.	60A below

# Electronic motor protection relays

## Direct mounting EMPR new/old comparative table

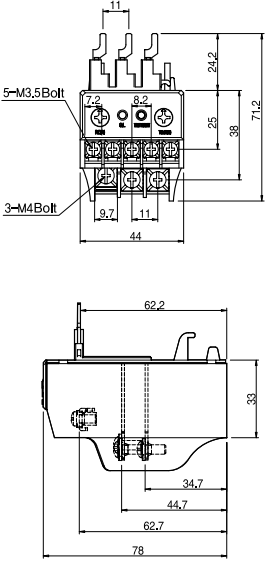
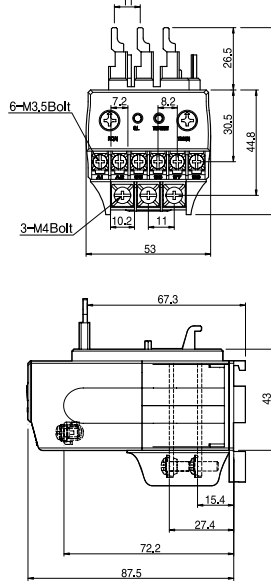
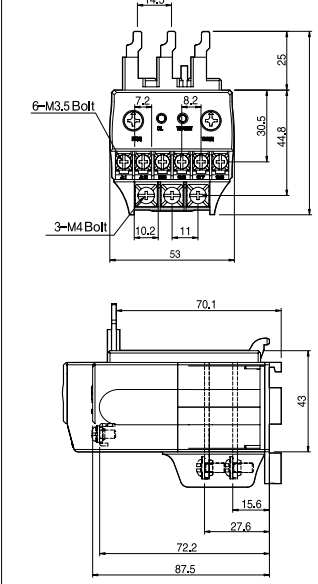
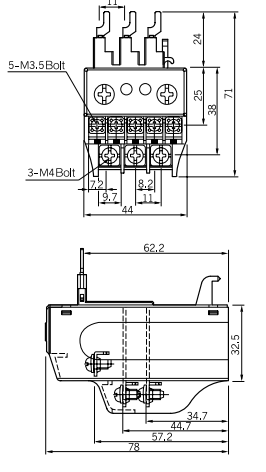
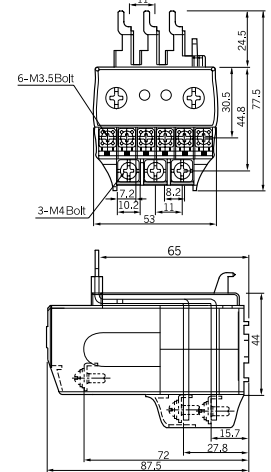
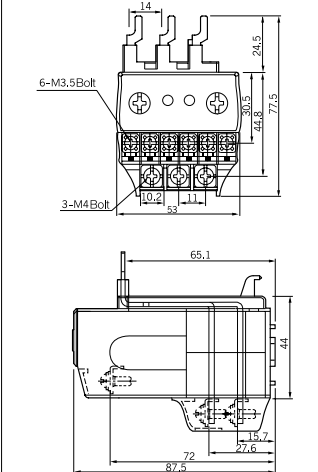
Type		GMP22-2P (1c) GMP22-2PD (1c)	GMP22-2P GMP22-2PA	GMP22-3P GMP22-3PR	GMP40-2P GMP40-2PD GMP40-2PA	GMP40-3P GMP40-3PR	
Number of sensors		2	2	3	2	3	
Protective function	Over current	✓	✓	✓	✓	✓	
	Phase failure	✓	✓	✓	✓	✓	
	Locked rotor	✓	✓	✓	✓	✓	
	Phase unbalance			✓	✓	✓	
	Reverse phase			✓ (PR)		✓ (PR)	
Aux. contact (at Energization)		1SPDT (1c)	2SPST (1a1b)		2SPST (1a1b)		
Rating Current		0.3~1.5, 1~5, 4.4~22A	0.3~1.5, 1~5, 4.4~22A		4~20, 8~40A		
Metasol (New)	EMPR Dimension						
	Type of contactors	MC-9b, 12b, 18b, 22b	MC-9b, 12b, 18b, 22b		MC-32a, 40a		
Meta-MEC (Old)	EMPR Dimension						
	Type of contactors	GMC-9, 12, 18, 22	GMC-9, 12, 18, 22		GMC-32, 40		
Wiring/Mounting Compatibility <sup>Note)</sup>		NO		NO		NO	
Retrofit Type (Tunnel)		GMP60T (1c) GMP22-2T	GMP22-2T GMP60TA (1c)	GMP22-3T GMP22-3TR	GMP40-2T GMP60T (1c) GMP60TA (1c)	GMP40-3T GMP40-3TR	

Note) If you want to use Metasol EMPR with GMC Contactors, only tunnel type EMPR is available.